

Brushless Motors/AC Speed Control Motors

## Brushless Motors

# DC Input



**DC Input**  
**BLH Series**

**DC Input**  
**BLV Series**



Introduction

AC Input  
 BX  
 BLF  
 BLE  
 BLU

DC Input  
 BLH  
 BLV

AC Speed Control Motors  
 BHF  
 FE100/  
 FE200  
 ES01/  
 ES02  
 US

Accessories  
 Installation

Page

<b>BLH Series</b> .....	D-132
<b>BLV Series</b> .....	D-148

# Brushless Motors BLH Series

● Additional Information ●  
 Technical reference → Page G-1  
 Safety standards → Page H-2

The **BLH** Series combines a slim, high-power brushless motor with a 24 VDC board-type driver to meet your space-saving needs. Speed control range is 100 to 3000 r/min.

Choose from a wide variety of frame sizes offering outputs of 15 to 100 W (1/50 to 1/8 HP) to meet your specific application.



● For detailed product safety standard information including standards, file number and certification body, please visit [www.orientalmotor.com](http://www.orientalmotor.com).

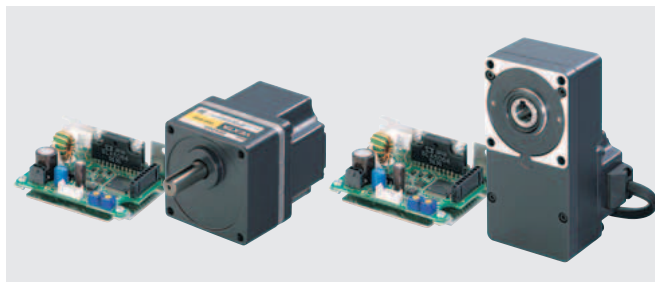

## Features

### ● Compact Board-Type Driver

The models with an output of 15 to 50 W (1/50 to 1/15 HP) adopt a compact, board-type driver smaller than the size of a business card. This will help to reduce the size of your equipment.

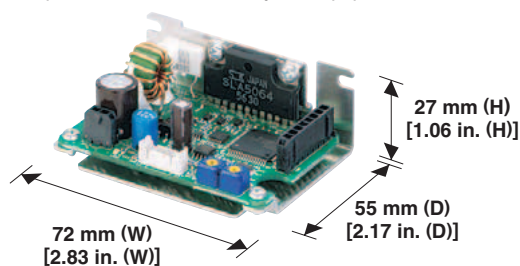

The 100 W (1/8 HP) driver has dimensions of 71 mm (D) × 131 mm (W) × 37.5 mm (H) [2.80 in. (D) × 5.16 in. (W) × 1.48 in. (H)]

### ◇ Full Range of Driver Functions

The compact driver is packed with a full range of functions.

- Instantaneous stop
- Speed control by potentiometer
- Speed control by DC voltage
- Acceleration/deceleration time setting
- Alarm output

### ● Speed Control Range

100 to 3000 r/min (speed ratio 30:1)

### ● Wide Variety

The series offers a wide range of models from compact packages with a motor output of 15 W (1/50 HP), to larger ones producing a high output of 100 W (1/8 HP). Choose one that best suits your specific requirements.

### ● IP65 Motor Structure\*

The motor is protected against water intrusion, should water come into contact with the motor.

\*IP40 for 15 W (1/50 HP) motor

- The motor must not be washed with water, and is not suitable for use in an environment where it constantly comes into contact with water.

### ● Long Life Gearhead Rating of 10000 Hours\*

The rated life of the parallel shaft gearhead and hollow shaft flat gearhead is 10000 hours. The parallel shaft gearhead achieves a rated life of twice as long as that of a conventional gearhead.

\*5000 hours for gearhead equipped with 15 W (1/50 HP) geared motor.

- The 50 W (1/15 HP) and 100 W (1/8 HP) parallel shaft gearhead has a tapped hole at the shaft end.

### ● Features of Hollow Shaft Flat Gearhead

#### ◇ Space-Saving and Low-Cost

The output shaft can be coupled directly to a driven shaft without using a coupling, which allows you to reduce the size and installation space of your equipment. Since no shaft-coupling parts are needed, the parts cost and labor will also decrease.

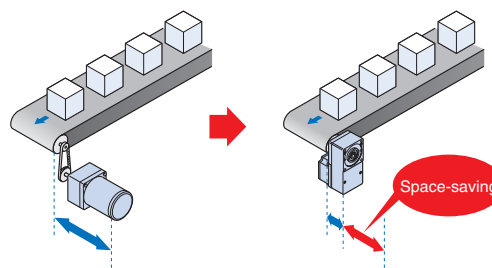

[For Three-Phase Motor and Parallel Shaft Gearhead]

[For Brushless Motor and Hollow Shaft Flat Gearhead]

#### ◇ High Permissible Torque

While the permissible torque of the parallel shaft gearhead saturates at high gear ratios, the hollow shaft flat gearhead enables the motor torque to be fully utilized.

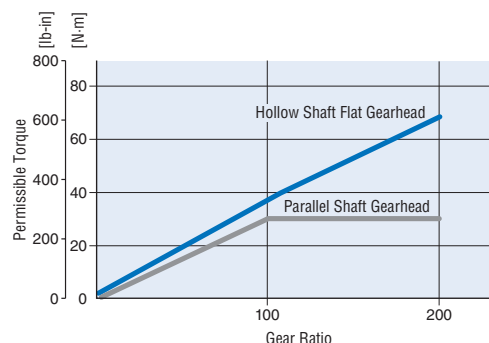

[Frame Size 90 mm (3.54 in.)]

## System Configuration

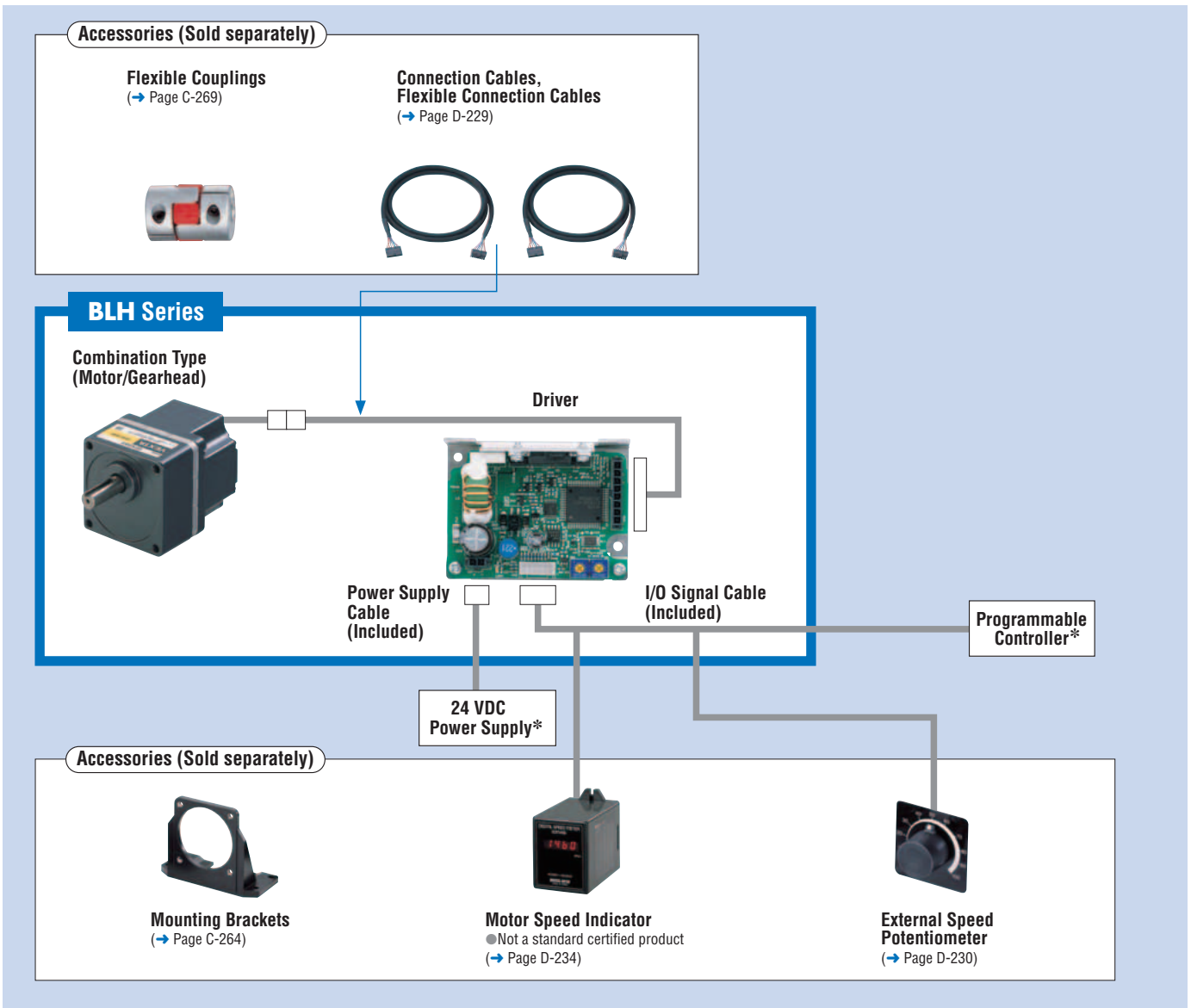

### ● Example of System Configuration

BLH Series Combination Type – Parallel Shaft <b>BLH450KC-30</b>	Sold Separately				
	Connection Cable [1.5 m (4.9 ft.)] <b>CC02BLH</b>	Motor Speed Indicator <b>SDM496</b>	External Speed Potentiometer <b>PAVR-20KZ</b>	Mounting Bracket <b>SOL4M6</b>	Flexible Coupling <b>MCL515F10</b>

● The system configuration shown above is an example. Other combinations are available.

\* Not supplied

Product Number Code

**BLH 2 30 K C - 5 FR**

① ② ③ ④ ⑤ ⑥ ⑦

①	Series	<b>BLH: BLH Series</b>
②	Motor Frame Size	<b>0:</b> 42 mm (1.65 in.) <b>2:</b> 60 mm (2.36 in.) <b>4:</b> 80 mm (3.15 in.) <b>5:</b> 90 mm (3.54 in.)
③	Output Power (W)	(Example) <b>30:</b> 30 W (1/25 HP)
④	Power Supply Voltage	<b>K:</b> 24 VDC
⑤	C: Cable Type	
⑥	Gear Ratio/Shaft Type	Number: Gear ratio for combination types: 8 types from <b>5</b> to <b>200</b> Gear ratio for geared types: 7 types from <b>5</b> to <b>100</b> <b>A:</b> Round Shaft Type
⑦	Blank: Combination Type – Parallel Shaft Gearhead <b>FR:</b> Combination Type – Hollow Shaft Flat Gearhead	

Product Line

**Combination Type** The combination type comes with the motor and its dedicated gearhead pre-assembled which simplifies installation in equipment. Motors and gearheads are also available separately to facilitate changes or repairs.  
**Geared Type** The geared type has an integrated motor and gearhead. The combination of motor and gearhead cannot be changed.

Geared Type/Combination Type – Parallel Shaft Gearhead

Type	Output Power	Model	Gear Ratio
Geared Type	15 W (1/50 HP)	<b>BLH015K-□</b>	<b>5, 10, 15, 20, 30, 50, 100</b>
	30 W (1/25 HP)	<b>BLH230KC-□</b>	<b>5, 10, 15, 20, 30, 50, 100, 200</b>
Combination Type	50 W (1/15 HP)	<b>BLH450KC-□</b>	<b>5, 10, 15, 20, 30, 50, 100, 200</b>
	100 W (1/8 HP)	<b>BLH5100KC-□</b>	<b>5, 10, 15, 20, 30, 50, 100, 200</b>

The following items are included in each product.  
Motor, Driver, Gearhead, I/O Signal Cable, Power Supply Cable, Mounting Screws\*, Parallel Key\*\*, Operating Manual  
\*1 Only for combination type  
\*2 Only for the products with a key slot on the output shaft

Combination Type – Hollow Shaft Flat Gearhead

Output Power	Model	Gear Ratio
30 W (1/25 HP)	<b>BLH230KC-□FR</b>	<b>5, 10, 15, 20, 30, 50, 100, 200</b>
50 W (1/15 HP)	<b>BLH450KC-□FR</b>	<b>5, 10, 15, 20, 30, 50, 100, 200</b>
100 W (1/8 HP)	<b>BLH5100KC-□FR</b>	<b>5, 10, 15, 20, 30, 50, 100, 200</b>

The following items are included in each product.  
Motor, Driver, Gearhead, I/O Signal Cable, Power Supply Cable, Mounting Screws, Parallel Key, Safety Cover (with screws), Operating Manual

Round Shaft Type

Output Power	Model
15 W (1/50 HP)	<b>BLH015K-A</b>
30 W (1/25 HP)	<b>BLH230KC-A</b>
50 W (1/15 HP)	<b>BLH450KC-A</b>
100 W (1/8 HP)	<b>BLH5100KC-A</b>

The following items are included in each product.  
Motor, Driver, I/O Signal Cable, Power Supply Cable, Operating Manual

Specifications

15 W (1/50 HP), 30 W (1/25 HP), 50 W (1/15 HP), 100 W (1/8 HP) (RoHS)



Model	Geared Type/Combination Type – Parallel Shaft Gearhead					
	Combination Type – Hollow Shaft Flat Gearhead					
	Round Shaft Type					
	<b>BLH015K-□</b>	<b>BLH230KC-□</b>	<b>BLH450KC-□</b>	<b>BLH5100KC-□</b>		
	-					
	<b>BLH015K-A</b>	<b>BLH230KC-A</b>	<b>BLH450KC-A</b>	<b>BLH5100KC-A</b>		
Rated Output Power (Continuous)	W (HP)	15 (1/50)	30 (1/25)	50 (1/15)	100 (1/8)	
Power Source	Rated Voltage	24 VDC				
	Permissible Voltage Range	±10%				
	Rated Input Current	A	1.0	2.1	3.1	6.0
	Maximum Input Current	A	2.4	3.7	5.4	9.8
Rated Torque	N·m (oz·in)	0.05 (7.1)	0.12 (17)	0.2 (28)	0.4 (56)	
Starting Torque*	N·m (oz·in)	0.075 (10.6)	0.15 (21)	0.24 (34)	0.5 (71)	
Rated Speed	r/min	3000		2500		
Speed Control Range	r/min	100~3000				
Round Shaft Type						
Permissible Load Inertia J	×10 <sup>-4</sup> kg·m <sup>2</sup> (oz·in <sup>2</sup> )	0.5 (2.7)	1.8 (9.8)	3.3 (18.1)	5.6 (31)	
Rotor Inertia J	×10 <sup>-4</sup> kg·m <sup>2</sup> (oz·in <sup>2</sup> )	0.032 (0.175)	0.087 (0.48)	0.23 (1.26)	0.61 (3.3)	
Speed Regulation	Load	±0.5% max. (0~Rated torque, at rated speed, at rated voltage, at normal ambient temperature)				
	Voltage	±0.5% max. (Rated voltage ±10%, at rated speed, with no load, at normal ambient temperature)				
	Temperature	±0.5% max. [0~+50°C (+32~+122°F), at rated speed, with no load, at rated voltage]				

\*The time during which the starting torque is effective is no more than 5 seconds and at 2000 r/min or below.  
● The values for each specification apply to the motor only.

● Enter the gear ratio in the box (□) within the model name.

## Speed – Torque Characteristics

Continuous Duty Region: Continuous operation is possible in this region.

Limited Duty Region: This region is used primarily when accelerating. When a load that exceeds the rated torque is applied continuously for approximately five seconds, overload protection is activated and the motor coasts to a stop.

### BLH015K-□/BLH015K-A

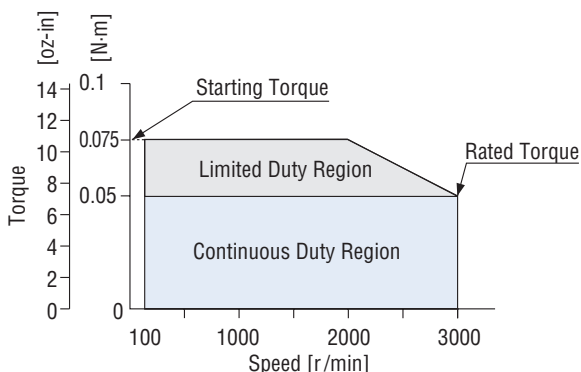

### BLH230KC-□/BLH230KC-□FR/BLH230KC-A

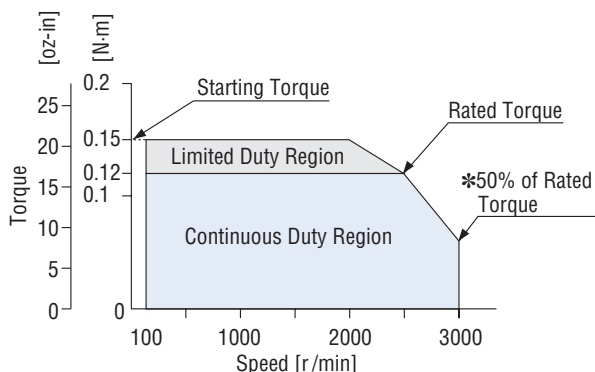

\* Value for 24 VDC with no connection cable

### BLH450KC-□/BLH450KC-□FR/BLH450KC-A

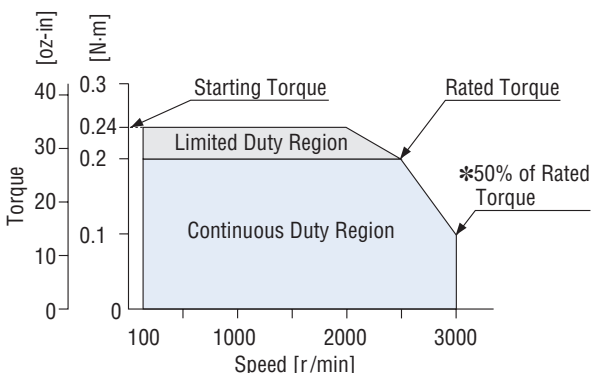

### BLH5100KC-□/BLH5100KC-□FR/BLH5100KC-A

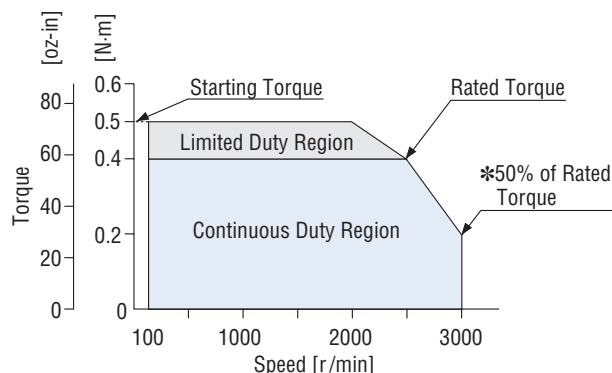

\* Value for 24 VDC with no connection cable

\* Value for 24 VDC with no connection cable

- For geared types and combination types, the values are for the motor only.
- Enter the gear ratio in the box (□) within the model name.

## Common Specifications

Item	Specifications
Speed Setting Method	Select one of the following methods: · Set using the internal speed potentiometer · Set using an accessory external speed potentiometer: <b>PAVR-20KZ</b> (20 kΩ, 1/4 W) (Sold separately) · Set using external DC voltage: 0~5 VDC, 1 mA or more (Input impedance 47 kΩ)
Acceleration/Deceleration Time	0.5~10 sec. <b>BLH015</b> : at 3000 r/min with no load <b>BLH230, BLH450, BLH5100</b> : at 2500 r/min with no load (The actual speed may change by load condition.) A common value is set using the acceleration/deceleration time potentiometer.
Multi-Speed Setting Method	Switching between 2 speeds One speed is set by the internal speed potentiometer (1 pc), while another speed is set by an external speed potentiometer (accessory <b>PAVR-20KZ</b> ) or by external DC voltage (0~5 VDC).
Input Signals	C-MOS negative logic input Operated by internal power supply Common to Start/Stop input, Run/Brake input, Direction of rotation input, Speed control method input and Alarm reset input
Output Signals	Open-collector output Operated by external power supply Use condition 26.4 VDC max., 10 mA max. Common to Alarm output and Speed output
Protective Functions*	When the following are activated, the motor will coast to a stop and the Alarm output will be OFF. The alarm LED on the driver will blink for the corresponding number of times shown in ( ). · Overload protection (2): Activated when the motor load exceeds rated torque for a minimum of 5 seconds. · Motor sensor error (3): Activated when the sensor wire inside the motor cable is disconnected during motor operation. · Overvoltage protection (4): Activated when the voltage applied to the driver exceeds 24 VDC by a minimum of approximately 15%, a gravitational operation is performed or a load exceeding the permissible load inertia is driven. · Undervoltage protection (5): Activated when the voltage applied to the driver falls below 24 VDC by a minimum of approximately 25%. · Overspeed protection (6): Activated when the motor speed exceeds 3500 r/min.
Maximum Cable Extension Distance	Motor/Driver Distance: 2 m (6.6 ft.) (when an accessory connection cable is used)
Time Rating	Continuous

\* With the **BLH** Series, the motor speed cannot be controlled in a gravitational operation or other application where the motor shaft is turned by the load. When a load exceeding the permissible load inertia is driven or a gravitational operation is performed, the overvoltage protective function will be activated and the motor will coast to a stop.

## General Specifications

Item	Motor	Driver	
Insulation Resistance	100 MΩ or more when 500 VDC megger is applied between the windings and the case after continuous operation under normal ambient temperature and humidity.	100 MΩ or more when 500 VDC megger is applied between the power supply terminal and heat sink after continuous operation under normal ambient temperature and humidity.	
Dielectric Strength	Sufficient to withstand 0.5 kVAC at 50 Hz applied between the windings and the case for 1 minute after continuous operation under normal ambient temperature and humidity.	Sufficient to withstand 0.5 kVAC at 50 Hz applied between the power supply terminal and heat sink for 1 minute after continuous operation under normal ambient temperature and humidity.	
Temperature Rise	50°C (90°F) or less in the windings, and 40°C (72°F) or less in the case*1, as measured by the thermocouple method after continuous operation under normal ambient temperature and humidity.	50°C (90°F) or less in the heat sink, as measured by the thermocouple method after continuous operation under normal ambient temperature and humidity.	
Operating Environment	Ambient Temperature	0~+50°C (+32~+122°F) (non-freezing)	
	Ambient Humidity	85% or less (non-condensing)	
	Altitude	Up to 1000 m (3300 ft.) above sea level	
	Atmosphere	No corrosive gases or dust. Cannot be used in a radioactive area, magnetic field, vacuum or other special environment	
Vibration	Not subject to continuous vibration or excessive impact In conformance with JIS C 60068-2-6, "Sine-wave vibration test method" Frequency range: 10~55 Hz Pulsating amplitude: 0.15 mm (0.006 in.) Sweep direction: 3 directions (X, Y, Z) Number of sweeps: 20 times		
Storage Condition*2	Ambient Temperature	-25~+70°C (-13~+158°F) (non-freezing)	
	Ambient Humidity	85% or less (non-condensing)	
	Altitude	Up to 3000 m (10000 ft.) above sea level	
Thermal Class	UL/CSA standards: 105 (A), EN standards: 120 (E)	-	
Degree of Protection	15 W (1/50 HP)	IP40	IP00
	30 W (1/25 HP), 50 W (1/15 HP), 100 W (1/8 HP)	IP65 (Excluding the mounting surface of the round shaft type and connectors)	

\*1 For round shaft types, please attach to the heat radiation plate (material: aluminum) of the following sizes to maintain a maximum motor case temperature of 90°C (194°F).  
(Except for **BLH015K-A**)

**BLH230KC-A:** 115×115 mm (4.53×4.53 in.), 5 mm (0.20 in.) thick

**BLH450KC-A:** 135×135 mm (5.31×5.31 in.), 5 mm (0.20 in.) thick

**BLH5100KC-A:** 200×200 mm (7.87×7.87 in.), 5 mm (0.20 in.) thick

\*2 The storage condition applies to a short period such as a period during transportation.

### Note

- Do not measure insulation resistance or perform the dielectric strength test while the motor and driver are connected.

## Gearmotor – Torque Table of Geared Type/Combination Type

### Geared Type/Combination Type – Parallel Shaft Gearhead

Unit = N·m (lb·in)

Model	Gear Ratio	Motor Speed	5	10	15	20	30	50	100	200
			100~2500 r/min	20~500	10~250	6.7~167	5~125	3.3~83	2~50	1~25
	3000 r/min	600	300	200	150	100	60	30	15	
<b>BLH015K-□</b>	100~3000 r/min	0.23 (2.0)	0.45 (3.9)	0.68 (6.0)	0.86 (7.6)	1.3 (11.5)	2 (17.7)	2 (17.7)	-	
<b>BLH230KC-□</b>	100~2500 r/min	0.54 (4.7)	1.1 (9.7)	1.6 (14.1)	2.2 (19.4)	3.1 (27)	5.2 (46)	6 (53)	6 (53)	
	3000 r/min	0.27 (2.3)	0.54 (4.7)	0.81 (7.1)	1.1 (9.7)	1.5 (13.2)	2.6 (23)	5.2 (46)	6 (53)	
<b>BLH450KC-□</b>	100~2500 r/min	0.90 (7.9)	1.8 (15.9)	2.7 (23)	3.6 (31)	5.2 (46)	8.6 (76)	16 (141)	16 (141)	
	3000 r/min	0.45 (3.9)	0.90 (7.9)	1.4 (12.3)	1.8 (15.9)	2.6 (23)	4.3 (38)	8.6 (76)	16 (141)	
<b>BLH5100KC-□</b>	100~2500 r/min	1.8 (15.9)	3.6 (31)	5.4 (47)	7.2 (63)	10.3 (91)	17.2 (152)	30 (260)	30 (260)	
	3000 r/min	0.90 (7.9)	1.8 (15.9)	2.7 (23)	3.6 (31)	5.2 (46)	8.6 (76)	17.2 (152)	30 (260)	

- A colored background (□) indicates gear shaft rotation in the same direction as the motor shaft, while the others rotate in the opposite direction.

### Combination Type – Hollow Shaft Flat Gearhead

Unit = N·m (lb·in)

Model	Gear Ratio	Motor Speed	5	10	15	20	30	50	100	200
			100~2500 r/min	20~500	10~250	6.7~167	5~125	3.3~83	2~50	1~25
	3000 r/min	600	300	200	150	100	60	30	15	
<b>BLH230KC-□FR</b>	100~2500 r/min	0.48 (4.2)	1.0 (8.8)	1.5 (13.2)	2.0 (17.7)	3.1 (27)	5.1 (45)	10.2 (90)	17 (150)	
	3000 r/min	0.24 (2.1)	0.51 (4.5)	0.77 (6.8)	1.0 (8.8)	1.5 (13.2)	2.6 (23)	5.1 (45)	10.2 (90)	
<b>BLH450KC-□FR</b>	100~2500 r/min	0.85 (7.5)	1.7 (15)	2.6 (23)	3.4 (30)	5.1 (45)	8.5 (75)	17 (150)	34 (300)	
	3000 r/min	0.43 (3.8)	0.85 (7.5)	1.3 (11.5)	1.7 (15)	2.6 (23)	4.3 (38)	8.5 (75)	17 (150)	
<b>BLH5100KC-□FR</b>	100~2500 r/min	1.7 (15)	3.4 (30)	5.1 (45)	6.8 (60)	10.2 (90)	17 (150)	34 (300)	68 (600)	
	3000 r/min	0.85 (7.5)	1.7 (15)	2.6 (23)	3.4 (30)	5.1 (45)	8.5 (75)	17 (150)	34 (300)	

- The flat gearhead rotates in the opposite direction to the motor when viewed from the front of the gearhead. It rotates in the same direction as the motor when viewed from the rear (motor mounting surface) of the gearhead. Rotation direction of the hollow shaft flat gearhead → Page D-243

- Enter the gear ratio in the box (□) within the model name.

## Permissible Overhung Load and Permissible Thrust Load

### Geared Type/Combination Type – Parallel Shaft Gearhead

Model	Gear Ratio	Permissible Overhung Load				Permissible Thrust Load	
		10 mm (0.39 in.) from shaft end		20 mm (0.79 in.) from shaft end		N	lb.
		N	lb.	N	lb.		
<b>BLH015K-□</b>	<b>5, 10, 15, 20, 30, 50, 100</b>	50	11.2	–	–	30	6.7
<b>BLH230KC-□</b>	<b>5</b>	100	22	150	33	40	9
	<b>10, 15, 20</b>	150	33	200	45		
	<b>30, 50, 100, 200</b>	200	45	300	67		
<b>BLH450KC-□</b>	<b>5</b>	200	45	250	56	100	22
	<b>10, 15, 20</b>	300	67	350	78		
	<b>30, 50, 100, 200</b>	450	101	550	123		
<b>BLH5100KC-□</b>	<b>5</b>	300	67	400	90	150	33
	<b>10, 15, 20</b>	400	90	500	112		
	<b>30, 50, 100, 200</b>	500	112	650	146		

### Combination Type – Hollow Shaft Flat Gearhead

Model	Gear Ratio	Permissible Overhung Load				Permissible Thrust Load	
		10 mm (0.39 in.) from mounting surface of gearhead		20 mm (0.79 in.) from mounting surface of gearhead		N	lb.
		N	lb.	N	lb.		
<b>BLH230KC-□FR</b>	<b>5, 10</b>	450	101	370	83	200	45
	<b>15, 20, 30, 50, 100, 200</b>	500	112	400	90		
<b>BLH450KC-□FR</b>	<b>5, 10</b>	800	180	660	148	400	90
	<b>15, 20, 30, 50, 100, 200</b>	1200	270	1000	220		
<b>BLH5100KC-□FR</b>	<b>5, 10</b>	900	200	770	173	500	112
	<b>15, 20</b>	1300	290	1110	240		
	<b>30, 50, 100, 200</b>	1500	330	1280	280		

● The permissible overhung load can also be calculated with a formula. Permissible overhung load calculation → Page D-242

### Round Shaft Type

Model	Permissible Overhung Load				Permissible Thrust Load
	10 mm (0.39 in.) from shaft end		20 mm (0.79 in.) from shaft end		
	N	lb.	N	lb.	
<b>BLH015K-A</b>	50	11.2	–	–	The permissible thrust load should not be greater than half the motor mass.
<b>BLH230KC-A</b>	70	15.7	100	22	
<b>BLH450KC-A</b>	120	27	140	31	
<b>BLH5100KC-A</b>	160	36	170	38	

## Permissible Load Inertia J of Geared Type/Combination Type

### Geared Type/Combination Type – Parallel Shaft Gearhead

Unit =  $\times 10^{-4}$  kg·m<sup>2</sup> (oz·in<sup>2</sup>)

Model	Gear Ratio	5	10	15	20	30	50	100	200
		<b>BLH015K-□</b>	3 (16)	14 (77)	30 (164)	50 (270)	120 (660)	300 (1640)	600 (3300)
<b>BLH230KC-□</b>	When instantaneous stop or instantaneous bi-directional operation is performed	0.4 (2.2)	1.7 (9.3)	3.9 (21)	7.0 (38)	15.7 (86)	43.7 (240)	43.7 (240)	–
		12 (66)	50 (270)	110 (600)	200 (1090)	370 (2000)	920 (5000)	2500 (13700)	5000 (27000)
<b>BLH450KC-□</b>	When instantaneous stop or instantaneous bi-directional operation is performed	1.55 (8.5)	6.2 (34)	14.0 (77)	24.8 (136)	55.8 (310)	155 (850)	155 (850)	155 (850)
		22 (120)	95 (520)	220 (1200)	350 (1910)	800 (4400)	2200 (12000)	6200 (34000)	12000 (66000)
<b>BLH5100KC-□</b>	When instantaneous stop or instantaneous bi-directional operation is performed	5.5 (30)	22 (120)	49.5 (270)	88 (480)	198 (1080)	550 (3000)	550 (3000)	550 (3000)
		45 (250)	190 (1040)	420 (2300)	700 (3800)	1600 (8800)	4500 (25000)	12000 (66000)	25000 (137000)

### Combination Type – Hollow Shaft Flat Gearhead

Unit =  $\times 10^{-4}$  kg·m<sup>2</sup> (oz·in<sup>2</sup>)

Model	Gear Ratio	5	10	15	20	30	50	100	200
		<b>BLH230KC-□FR</b>	12 (66)	50 (270)	110 (600)	200 (1090)	370 (2000)	920 (5000)	2500 (13700)
<b>BLH450KC-□FR</b>	When instantaneous stop or instantaneous bi-directional operation is performed	1.55 (8.5)	6.2 (34)	14.0 (77)	24.8 (136)	55.8 (310)	155 (850)	155 (850)	155 (850)
		22 (120)	95 (520)	220 (1200)	350 (1910)	800 (4400)	2200 (12000)	6200 (34000)	12000 (66000)
<b>BLH5100KC-□FR</b>	When instantaneous stop or instantaneous bi-directional operation is performed	5.5 (30)	22 (120)	49.5 (270)	88 (480)	198 (1080)	550 (3000)	550 (3000)	550 (3000)
		45 (250)	190 (1040)	420 (2300)	700 (3800)	1600 (8800)	4500 (25000)	12000 (66000)	25000 (137000)

● Enter the gear ratio in the box (□) within the model name.

## Dimensions Unit = mm (in.)

● Mounting screws are included with the combination type. Dimensions for mounting screws → Page D-242

### ● 15 W (1/50 HP)

#### ◇ Geared Type

##### BLH015K-□

Geared Motor: BLHM015K-□

Mass: 0.5 kg (1.10 lb.)

DXF A428

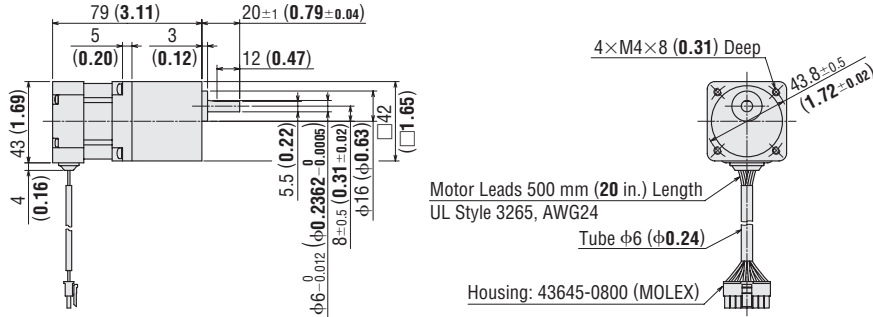

#### ◇ Round Shaft Type

##### BLH015K-A

Motor: BLHM015K-A

Mass: 0.25 kg (0.55 lb.)

DXF A429

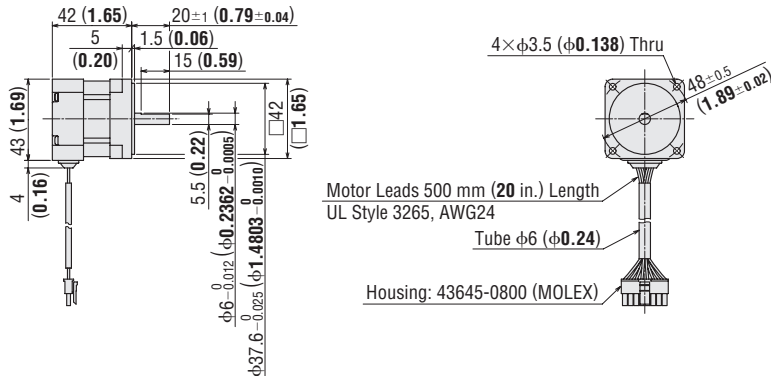

### ● 30 W (1/25 HP)

#### ◇ Motor/Parallel Shaft Gearhead

Model	Motor Model	Gearhead Model	Gear Ratio	L	Mass kg (lb.)	DXF
BLH230KC-□	BLHM230KC-GFS	GFS2G□	5~20	34 (1.34)	1.0 (2.2)	A430AU
			30~100	38 (1.50)		A430BU
			200	43 (1.69)	A430CU	

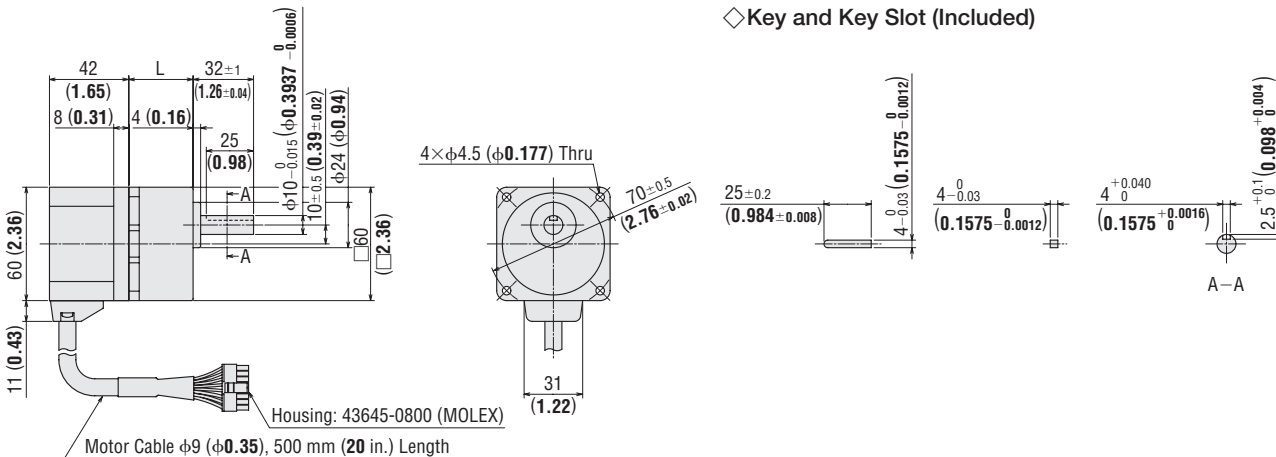

#### ◇ Key and Key Slot (Included)

● Enter the gear ratio in the box (□) within the model name.



## ◇ Motor/Hollow Shaft Flat Gearhead

### BLH230KC-□FR

Motor: BLHM230KC-GFS

Gearhead: GFS2G□FR

Mass: 1.3 kg (2.9 lb.) (Including gearhead)

**DXF** A431U

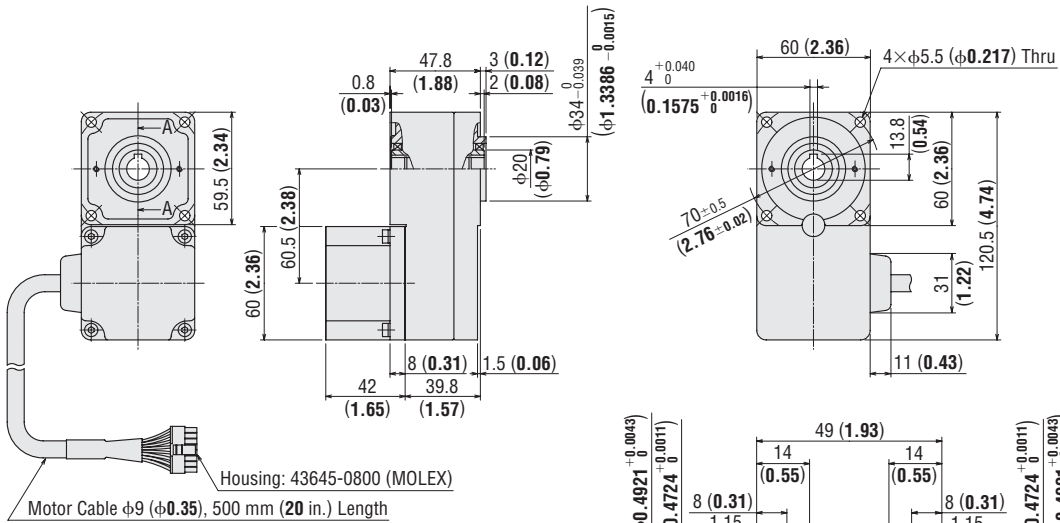

## ◇ Key (Included)

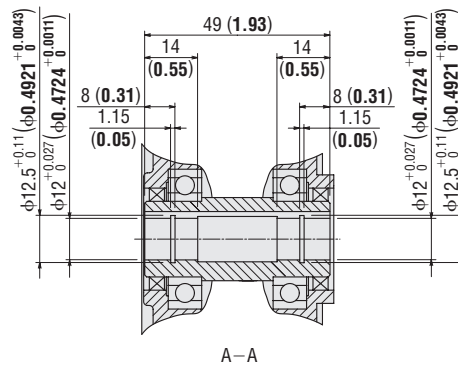
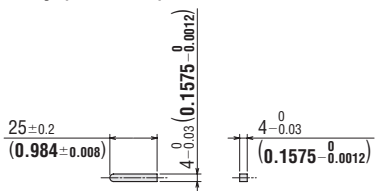

## ◇ Round Shaft Type

### BLH230KC-A

Motor: BLHM230KC-A

Mass: 0.5 kg (1.1 lb.)

**DXF** A432U

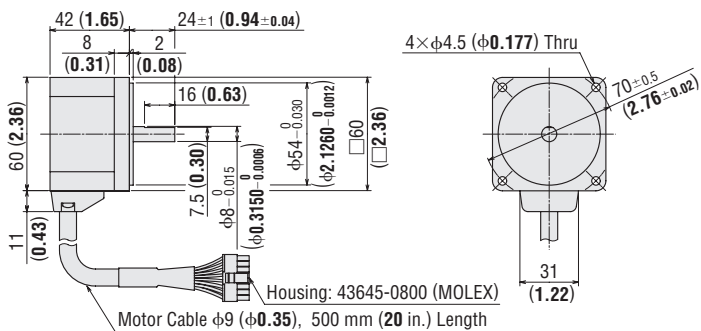

● Enter the gear ratio in the box (□) within the model name.

## ● 50 W (1/15 HP)

### ◇ Motor/Parallel Shaft Gearhead

Model	Motor Model	Gearhead Model	Gear Ratio	L	Mass kg (lb.)	DXF
<b>BLH450KC</b> -□	BLHM450KC-GFS	GFS4G□	<b>5~20</b>	41 (1.61)	1.8 (4.0)	A433AU
			<b>30~100</b>	46 (1.81)		A433BU
			<b>200</b>	51 (2.01)		A433CU

### ◇ Key and Key Slot (Included)

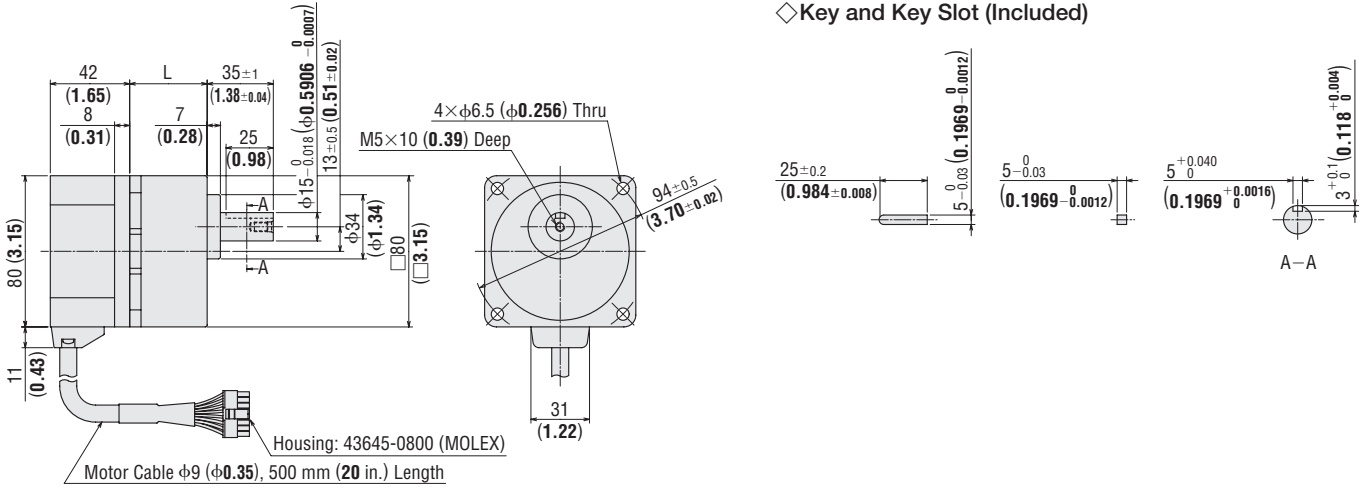

### ◇ Motor/Hollow Shaft Flat Gearhead

#### BLH450KC-□FR

Motor: BLHM450KC-GFS

Gearhead: GFS4G□FR

Mass: 2.4 kg (5.3 lb.) (Including gearhead)

**DXF** A434U

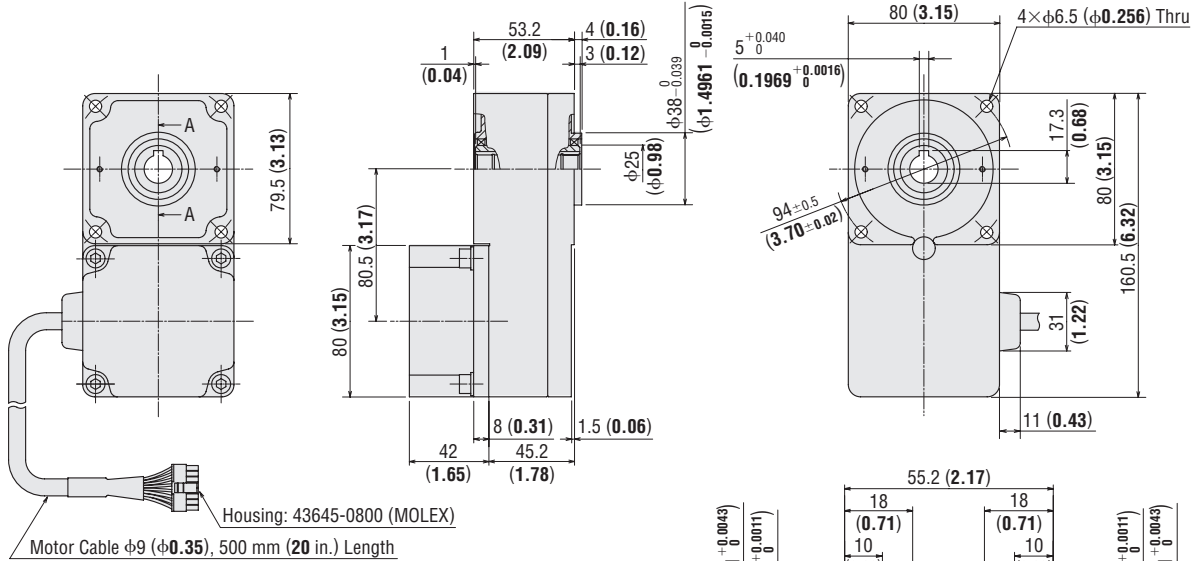

### ◇ Key (Included)



● Enter the gear ratio in the box (□) within the model name.

◇ Round Shaft Type

**BLH450KC-A**

Motor: BLHM450KC-A  
Mass: 0.8 kg (1.76 lb.)

DXF A435U

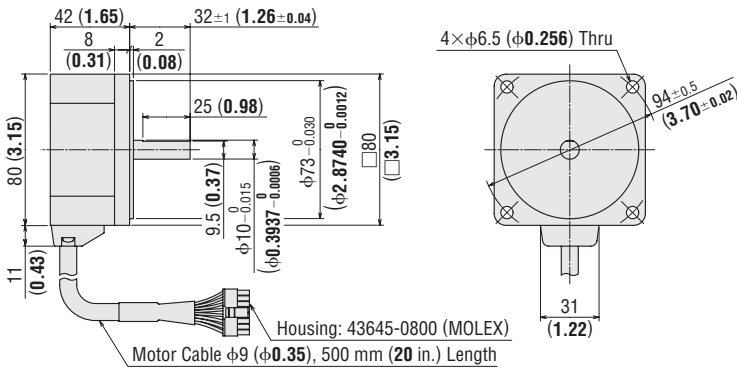

● 100 W (1/8 HP)

◇ Motor/Parallel Shaft Gearhead

Model	Motor Model	Gearhead Model	Gear Ratio	L	Mass kg (lb.)	DXF
<b>BLH5100KC-</b> □	BLHM5100KC-GFS	GFS5G□	5~20	45 (1.77)	2.9 (6.4)	A436AU
			30~100	58 (2.28)		A436BU
			200	64 (2.52)		A436CU

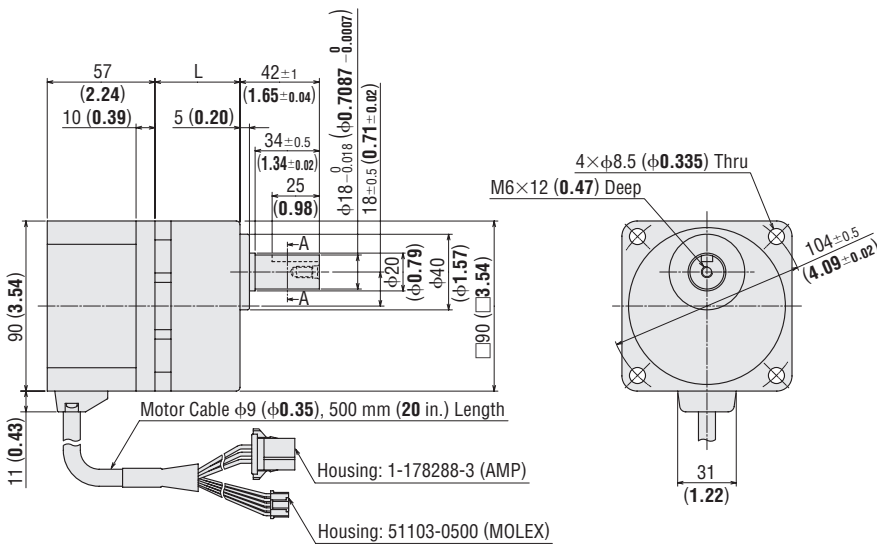

◇ Key and Key Slot (Included)

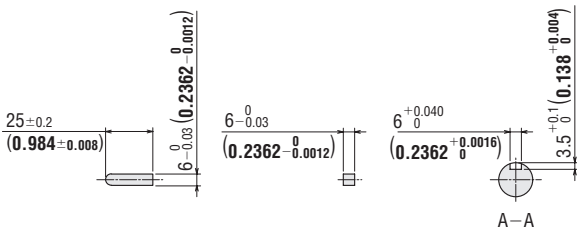

● Enter the gear ratio in the box (□) within the model name.

## ◇ Motor/Hollow Shaft Flat Gearhead

### BLH5100KC-□FR

Motor: BLHM5100KC-GFS

Gearhead: GFS5G□FR

Mass: 3.6 kg (7.9 lb.) (Including gearhead)

DXF A437U

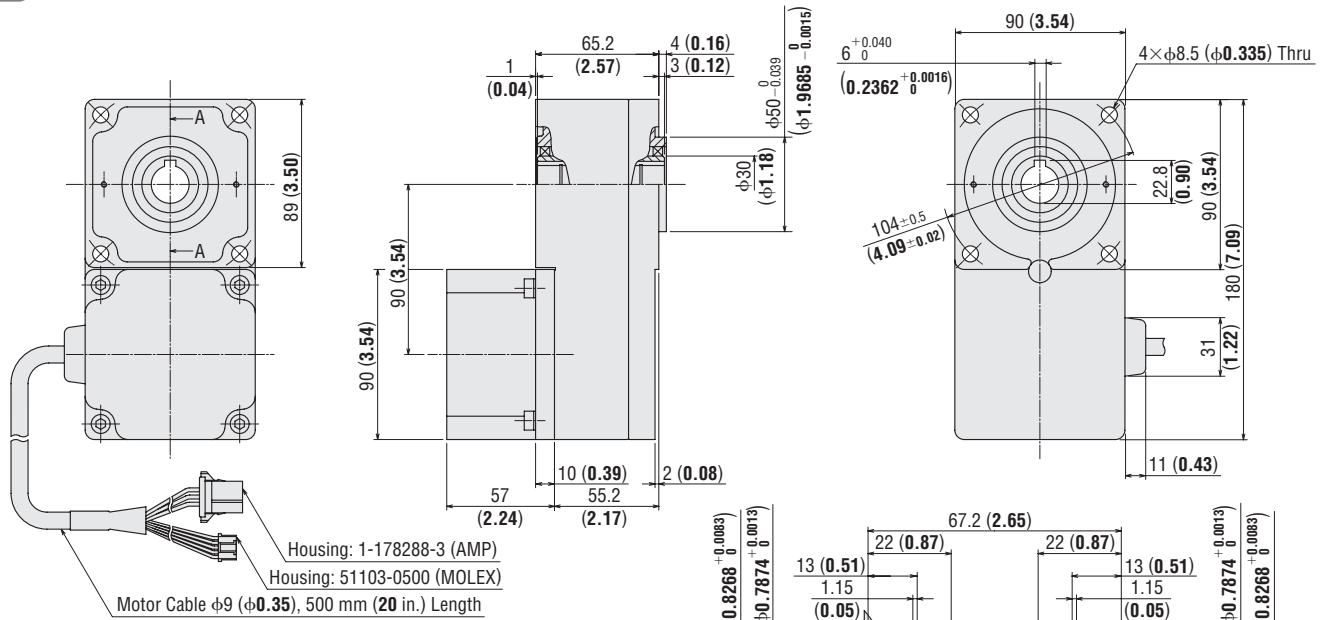

## ◇ Key (Included)

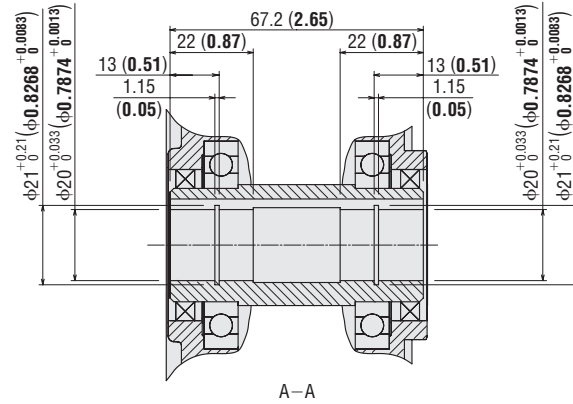
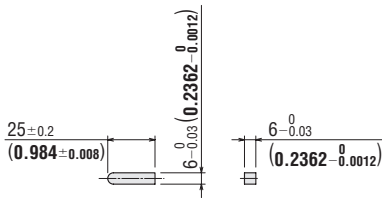

## ◇ Round Shaft Type

### BLH5100KC-A

Motor: BLHM5100KC-A

Mass: 1.4 kg (3.1 lb.)

DXF A438U

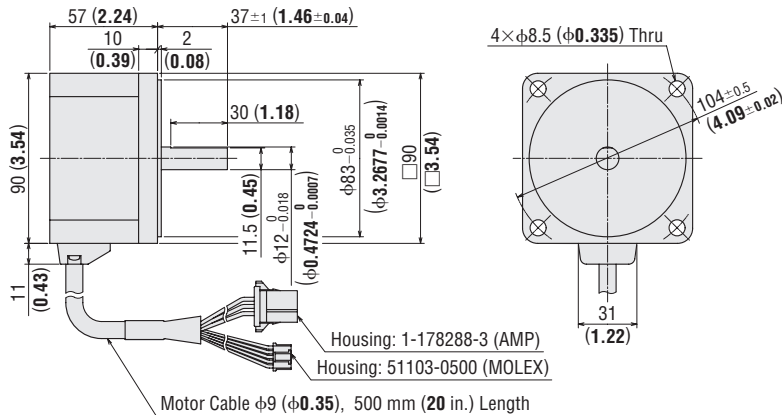

● Enter the gear ratio in the box (□) within the model name.

## ◇ Driver

BLHD15K, BLHD30K, BLHD50K

Mass: 0.1 kg (0.22 lb.)

DXF A439

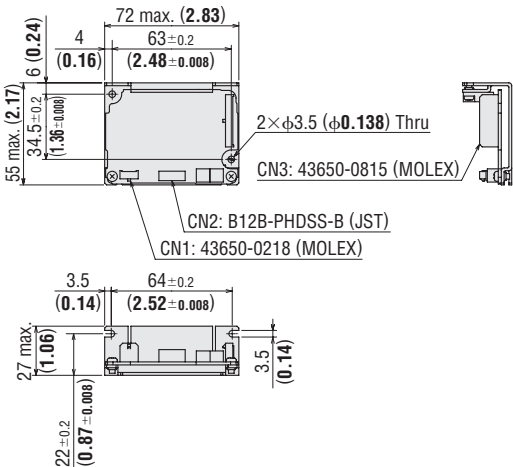

BLHD100K

Mass: 0.3 kg (0.66 lb.)

DXF A440

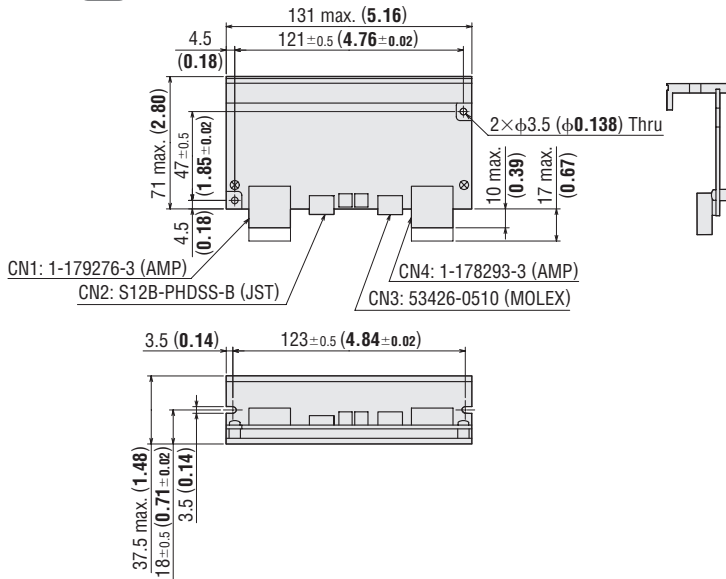

## ◇ Driver Input/Output Signal Cable (Included)

- For 15 W (1/50 HP), 30 W (1/25 HP), 50 W (1/15 HP), 100 W (1/8 HP)

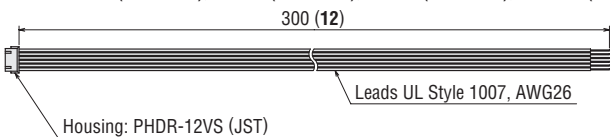

## ◇ Driver Power Supply Cable (Included)

- For 15 W (1/50 HP), 30 W (1/25 HP), 50 W (1/15 HP)

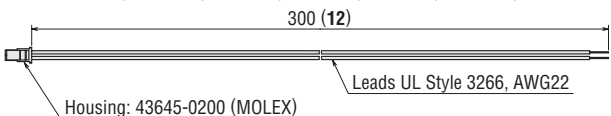

- For 100 W (1/8 HP)

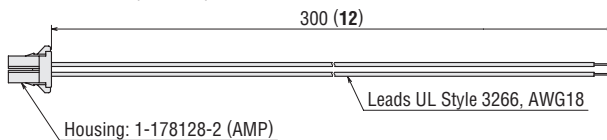

Introduction

BX

BLF

AC Input

BLE

BLU

BH

DC Input

BIV

BHF

AC Speed Control Motors

FE100/  
FE200

ES01/  
ES02

US

Accessories

Installation

## Connection and Operation

### Names and Functions of Driver Parts

◇ 15 W (1/50 HP), 30 W (1/25 HP), 50 W (1/15 HP)

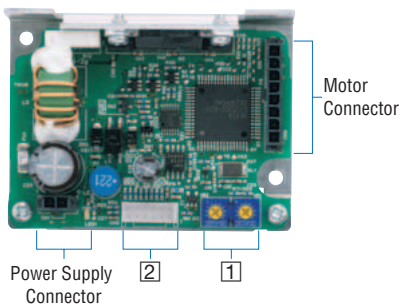

◇ 100 W (1/8 HP)

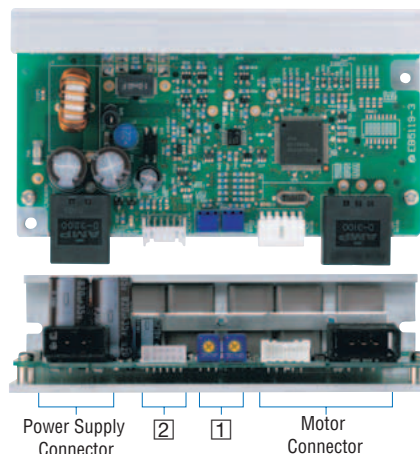

#### 1 Speed Potentiometers

Indication	Potentiometer Name	Function
VR1	Internal Speed Potentiometer	Set and adjust the operating speed of the motor.
VR2	Acceleration/Deceleration Time Potentiometer	Set a common acceleration/deceleration time in the range of 0.5 to 10 seconds.

#### 2 Input/Output Signals

Indication	Input/Output	Pin No.	Function
CN2	Output	1	ALARM Output
		2	SPEED Output
	I/O Signal Common	3	GND
		4	VRL Input
	Analog Input	5	VRM Input
		6	VRH Input
	Input	7	ALARM-RESET Input
		8	INT.VR/EXT Input
		9	CW/CCW Input
		10	RUN/BRAKE Input
		11	START/STOP Input
		12	NC

### Connection Diagrams

◇ 15 W (1/50 HP), 30 W (1/25 HP), 50 W (1/15 HP)

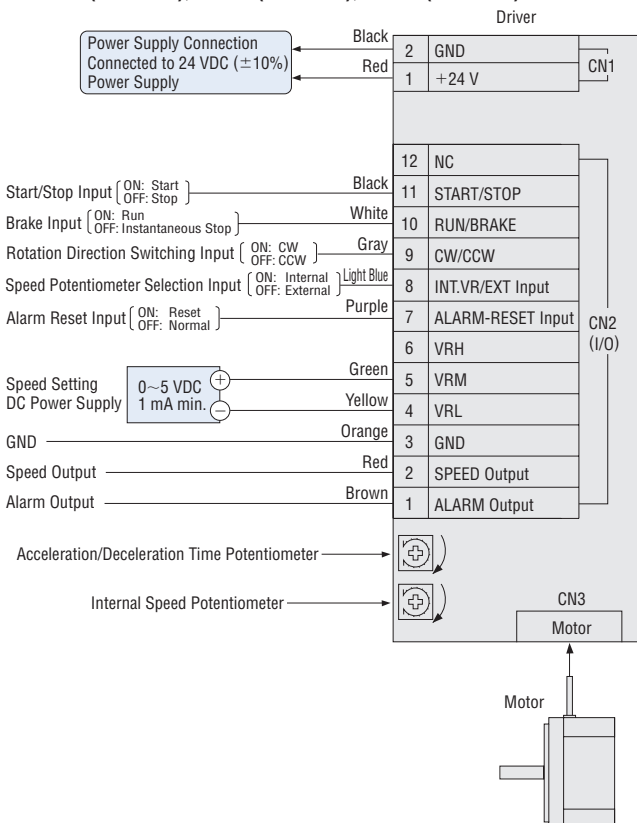

◇ 100 W (1/8 HP)

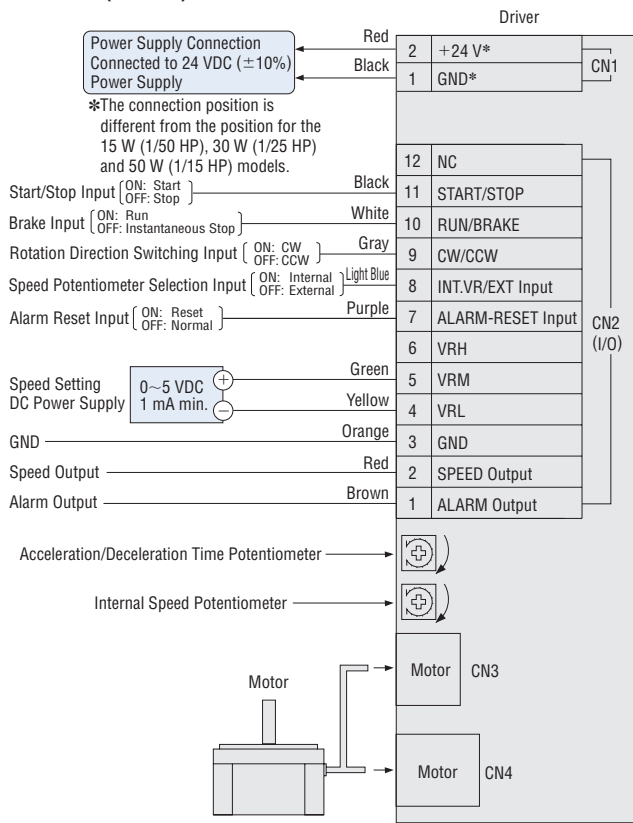

## ● Timing Chart

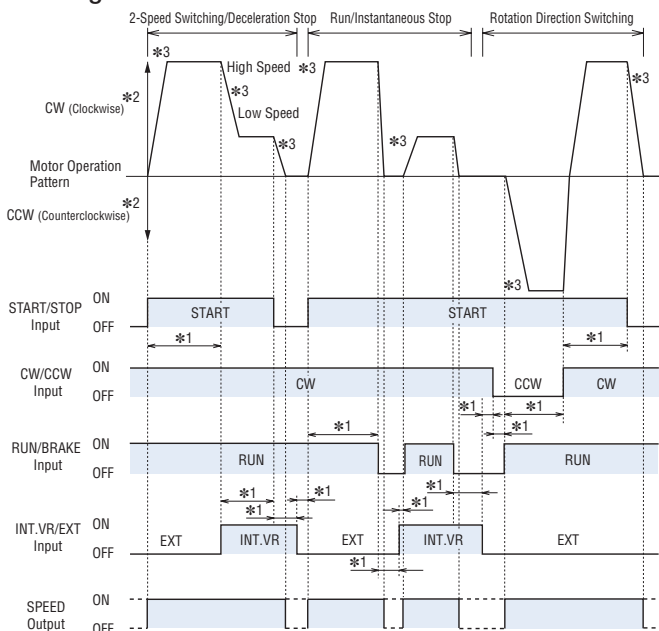

- \*1 At least 10 ms
- \*2 The direction applies to the motor alone. The specific direction will vary depending on the gear ratio.
- \*3 The motor will start over the time set by the acceleration/deceleration time potentiometer.

## ● Input/Output Signal Circuits

### ◇ Input Circuit

The driver's signal inputs use the C-MOS input method. The signal status indicates a voltage level of 0 to 0.5 VDC when the signal is ON, or 4 to 5 VDC when it is OFF.

#### ● 5 VDC C-MOS Output from External Control Device

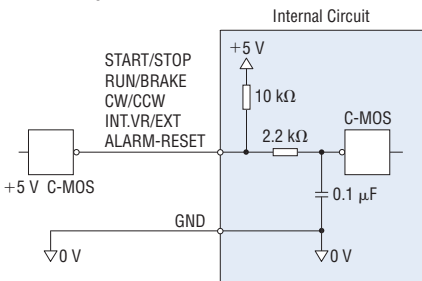

#### ● Open-Collector Output from External Control Device

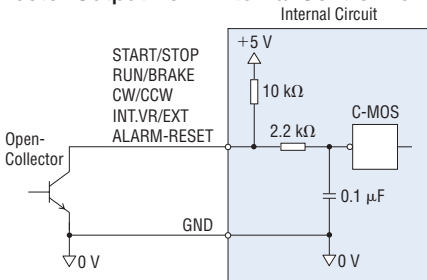

- All operations of run/stop, instantaneous stop and rotation direction switching operations can be controlled with the START/STOP, RUN/BRAKE and CW/CCW signals.
- If both the START/STOP signal and the RUN/BRAKE signal are set to ON, the motor rotates. The motor will accelerate over the time set by the acceleration/deceleration time potentiometer. During this time, if the CW/CCW signal is set to ON, the motor rotates clockwise as viewed from the shaft end of the motor; if the CW/CCW signal is set to OFF, the motor rotates in the counterclockwise direction.
- If the RUN/BRAKE signal is set to OFF while the START/STOP signal is ON, the motor stops instantaneously. If the START/STOP signal is set to OFF while the RUN/BRAKE signal is ON, the motor will stop with deceleration time set by the acceleration/deceleration time potentiometer.
- The duration of each input signal must be 10 ms or longer.
- Do not operate (turn ON/OFF) two or more input signals simultaneously. There must be a minimum interval of 10 ms before another input signal can be operated after an input signal has been operated.

### ● Switch Connection

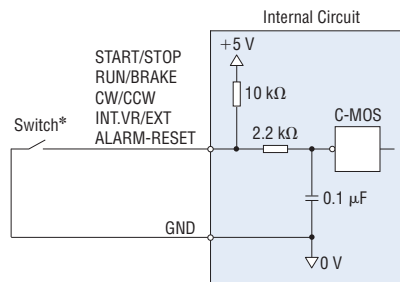

\* Use a switch capable of opening/closing the current flow at 5 VDC, 1 mA maximum.

### ◇ Output Circuit

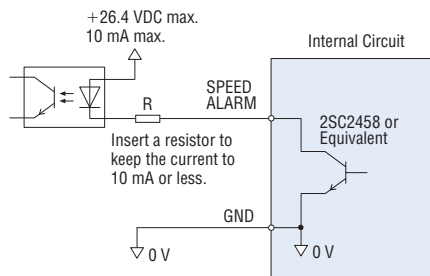

+26.4 VDC max.  
10 mA max.

Insert a resistor to keep the current to 10 mA or less.

## ◇ SPEED Output

The system outputs pulse signals (with a width of 0.3 ms) at a rate of 30 pulses per rotation of the motor output shaft synchronized with the motor operation.

You can measure the SPEED output frequency and calculate the motor speed.

$$\text{Motor speed (r/min)} = \frac{\text{SPEED output frequency [Hz]}}{30} \times 60$$

$$\text{SPEED output frequency (Hz)} = \frac{1}{T}$$



## ◇ ALARM Output

The ALARM output is normally ON and goes OFF when there is an alarm.

## ◇ ALARM-RESET

When the motor is stopped, setting this signal ON, then returning it to OFF resets the alarm.

Please return either the START/STOP input or the RUN/BRAKE input to OFF before inputting the ALARM-RESET. The ALARM-RESET is not accepted if both these signals are ON.

### Notes

- Output signal is open-collector output, so an external power supply (Vcc) is required.
- Use a power supply of no more than 26.4 VDC and connect a limit resistor (R) so that the output current does not exceed 10 mA. When using neither the speed output function nor the alarm output function, this connection is not required.

## ● Speed Setting Method

### ◇ Internal Speed Potentiometer

When INT.VR/EXT input is set to ON, the speed can be set with the internal speed potentiometer.

There is no need for this connection when the internal speed potentiometer is not used.

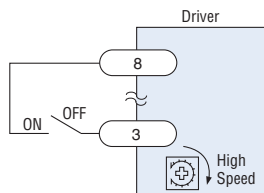

### ◇ External Speed Potentiometer (Sold separately)

When separating the motor speed setting from the driver, connect the accessory external speed potentiometer as follows.

External Speed Potentiometer **PAVR-20KZ** (Sold separately)

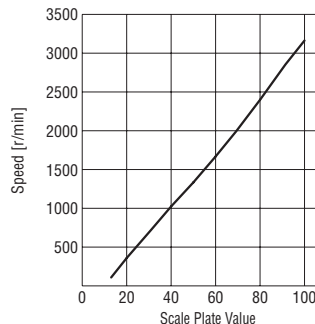
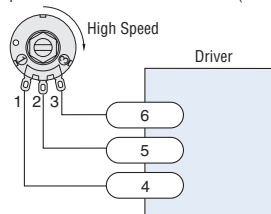

External Speed Potentiometer Scale-Speed Characteristics (Representative values)

### ◇ External DC Voltage

When setting the motor speed with an external DC voltage, do so in the following manner.

External DC Power Supply

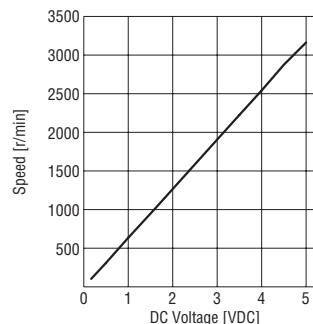
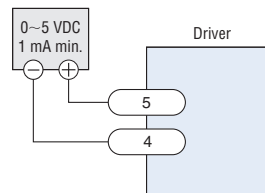

External DC Voltage-Speed Characteristics (Representative values)

### Note

- The speed in the graph represents the speed of a motor alone. The gearhead output shaft speed of the combination type or geared type is calculated by dividing the graph speed by the gear ratio.



## ● Multi-Motor Control

Two or more sets of motors and drivers can be operated at the same speed by using a DC power supply or an external speed potentiometer.

### ◇ When External DC Power Supply is Used

- Use a DC power supply with current capacity equal to or greater than the value obtained by the following expression.

Current capacity (N is the number of drivers)  $I = 1 \times N$  (mA)

Example: When two drivers are used, current capacity should be at least 2 mA.

- Connect the other input/output lines to each driver individually.
- Motor speed differences can be adjusted by connecting a resistor of 1.5 kΩ, 1/4 W to the M terminal of the first driver, and a 5 kΩ, 1/4 W variable resistor (VRn) to the M terminals of the other drivers.

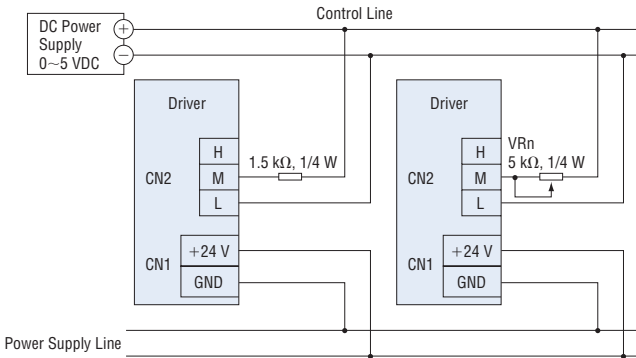

### ◇ When External Speed Potentiometer is Used

As shown below, make the power supply line and the speed control line common to set the speed at VRx.

- The required resistance of the external speed potentiometer is calculated by the following expression.

Resistance value (N is the number of drivers)  $VRx = 20/N$  (kΩ),  $N/4$  (W)

Example: When two drivers are used, the resistance is 10 kΩ, 1/2 W.

- Connect the other input/output lines to each driver individually.
- Motor speed differences can be adjusted by connecting a resistor of 1.5 kΩ, 1/4 W to the M terminal of the first driver, and a 5 kΩ, 1/4 W variable resistor (VRn) to the M terminals of the other drivers.
- No more than five motors should be operated simultaneously when using the external speed potentiometer.

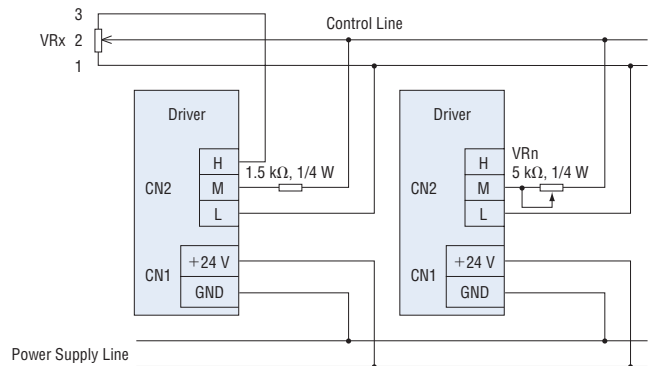

## List of Motor and Driver Combinations

### ● Geared Type

The geared type has an integrated motor and gearhead. The combination of motor and gearhead cannot be changed.

Output Power	Model	Geared Motor Model	Driver Model
15 W (1/50 HP)	<b>BLH015K</b> -□	BLHM015K-□	BLHD15K

### ● Combination Type – Parallel Shaft Gearhead

The combination type comes with the motor and parallel shaft gearhead pre-assembled.

Output Power	Model	Motor Model	Gearhead Model	Driver Model
30 W (1/25 HP)	<b>BLH230KC</b> -□	BLHM230KC-GFS	GFS2G□	BLHD30K
50 W (1/15 HP)	<b>BLH450KC</b> -□	BLHM450KC-GFS	GFS4G□	BLHD50K
100 W (1/8 HP)	<b>BLH5100KC</b> -□	BLHM5100KC-GFS	GFS5G□	BLHD100K

### ● Combination Type – Hollow Shaft Flat Gearhead

The combination type comes with the motor and hollow shaft flat gearhead pre-assembled.

Output Power	Model	Motor Model	Gearhead Model	Driver Model
30 W (1/25 HP)	<b>BLH230KC</b> -□ <b>FR</b>	BLHM230KC-GFS	GFS2G□FR	BLHD30K
50 W (1/15 HP)	<b>BLH450KC</b> -□ <b>FR</b>	BLHM450KC-GFS	GFS4G□FR	BLHD50K
100 W (1/8 HP)	<b>BLH5100KC</b> -□ <b>FR</b>	BLHM5100KC-GFS	GFS5G□FR	BLHD100K

### ● Round Shaft Type

Output Power	Model	Motor Model	Driver Model
15 W (1/50 HP)	<b>BLH015K-A</b>	BLHM015K-A	BLHD15K
30 W (1/25 HP)	<b>BLH230KC-A</b>	BLHM230KC-A	BLHD30K
50 W (1/15 HP)	<b>BLH450KC-A</b>	BLHM450KC-A	BLHD50K
100 W (1/8 HP)	<b>BLH5100KC-A</b>	BLHM5100KC-A	BLHD100K

- Enter the gear ratio in the box (□) within the model name.