



Network-Compatible Products, Controller



Overview of Network Compatible Products F-2

Network-Compatible Products Overview

Modbus (RTU)-Compatible Products F-6

Modbus (RTU)

EtherCAT-Compatible, CC-Link-Compatible, and MECHATROLINK-Compatible Products F-7

EtherCAT, CC-Link, MECHATROLINK

Network Converters F-8

Network Converters

Overview of Controllers F-10

Controller Overview

SCX11 F-12

SCX11

Overview of Network Compatible Products

Motor control via network communication can detect the status of the motor directly by data. This results in a shorter development period and increased reliability and maintainability of the equipment. By expanding the network compatible product lineup, Oriental Motor meets diversifying network environments of factory automation.

Features

Network-compatible products offer the following benefits:

- Simple wiring achieves space saving for wiring and smaller equipment size.
- Transmission distance can be extended up to several hundred meters. This makes wiring route design easier and enables products to be positioned in appropriate locations.
- Simple wiring achieves a reduction in the man-hours for the wiring process and in the cost of wiring.
- Operating status is monitored by product input/output information, alarm, etc. This achieves improved maintainability via the system.
- Simple wiring makes wiring and checking process easier when replacing the product.

Network Configuration Example

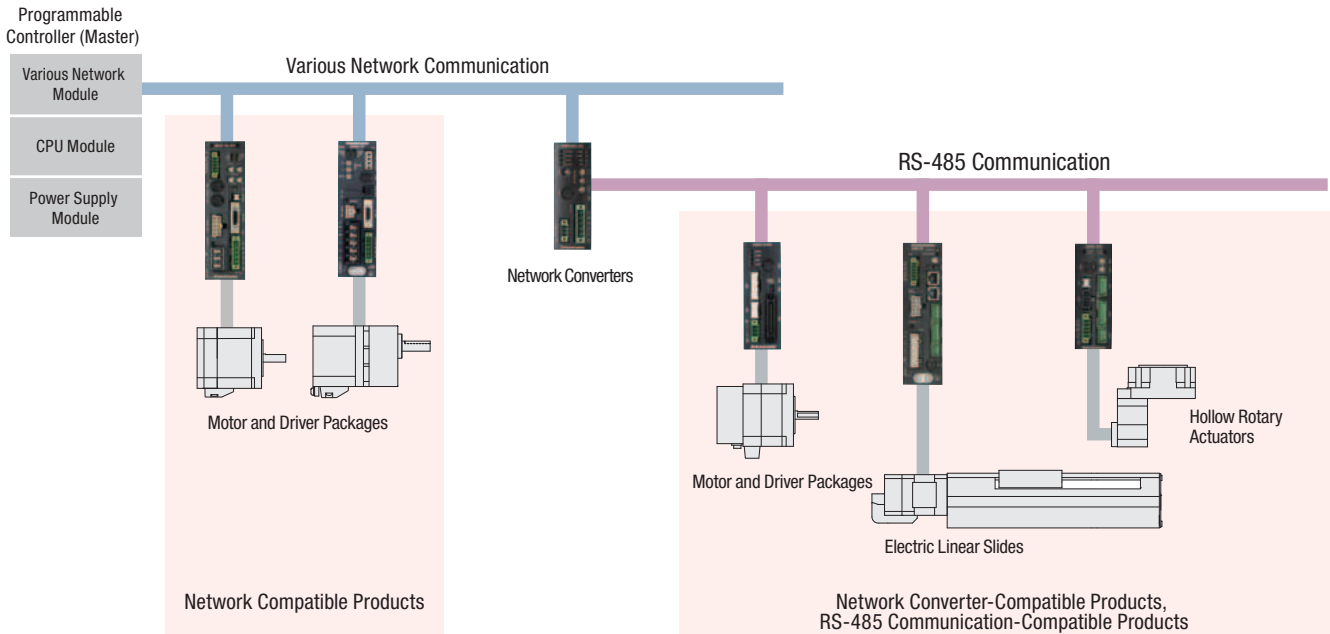

Compatible Network

Modbus (RTU)

Modbus is the open field network with Modbus Protocol installed. Modbus is used widely in the fields of factory and process automation because its protocol specification is open to the public and it is very simple.

*Modbus is a registered trademark of Schneider Automation Inc.

EtherCAT

EtherCAT is an Ethernet (IEEE802.3)-compliant, open, high-speed, industrial network system.

*EtherCAT® is registered trademark and patented technology, licensed by Beckhoff Automation GmbH, Germany.

CC-Link

CC-Link (Control&Communication Link) is the open field network promoted by CC-Link Partner Association.

*CC-Link is a registered trademark of CC-Link Partner Association.



MECHATROLINK

MECHATROLINK-II and MECHATROLINK-III are motion networks promoted by MECHATROLINK Members Association.

*MECHATROLINK is a registered trademark of MECHATROLINK Members Association.

Network Compatible Products

Built-in Controller Type Stepper Motors

Stepper Motors <i>αSTEP</i>		0.72° Stepper Motors
<p>AR Series</p>  <p>AC power supply input → Page A-20 DC power supply input → Page A-136</p>	<p>AZ Series</p>  <p>AC power supply input → Page A-74 DC power supply input → Page A-196</p>	<p>RKII Series</p>  <p>AC power supply input → Page A-84</p>

Brushless Motors



RS-485 Communication

BLE Series





AC power supply input → Page D-42

Linear & Rotary Actuators

Stepper Motors <i>αSTEP</i> Equipped with AR Series		
<p>EAS Series</p>  <p>AC/DC power supply input → Page E-16</p>	<p>EAC Series</p>  <p>AC/DC power supply input → Page E-56</p>	<p>DGII Series</p>  <p>AC/DC power supply input → Page E-118</p>

Network Converters

CC-Link-Compatible	MECHATROLINK-Compatible	EtherCAT-Compatible
<p>NETC01-CC</p>  <p>DC power supply input → Page F-8</p>	<p>NETC01-M2</p>  <p>DC power supply input → Page F-8</p>	<p>NETC01-ECT</p>  <p>DC power supply input → Page F-8</p>

Network-Compatible Products Overview

Modbus (RTU)

EtherCAT, CC-Link, MECHATROLINK

Network Converters

Controller Overview

SCX11

Equipped with Industrial Network Communications for Various Host Systems

FLEX is the collective name for industrial network communication products that support I/O control, Modbus (RTU) control, and FA network control via network converters. These products enable simple connection and simple control, shortening the total lead time for system construction.

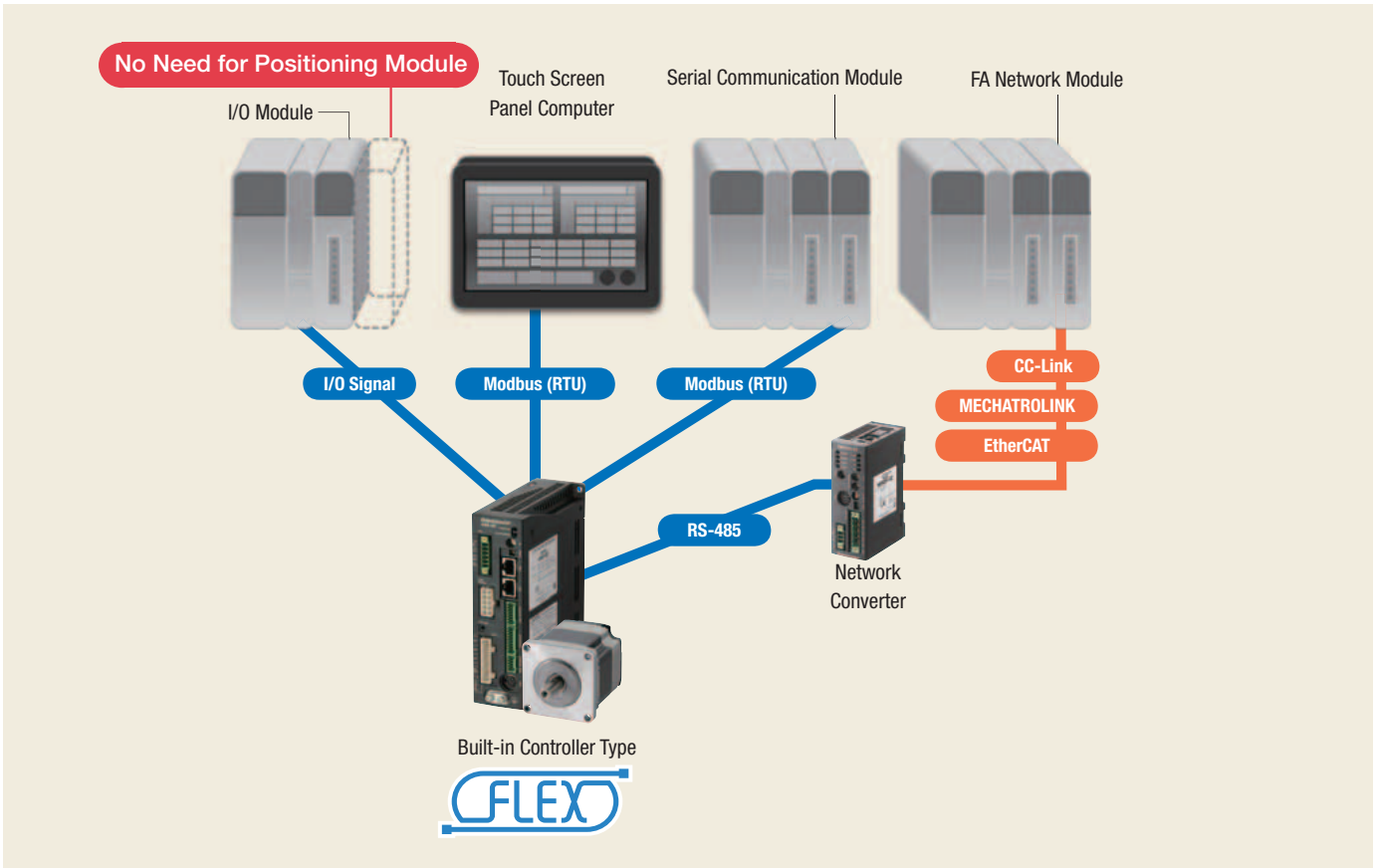

Advantages of FLEX Products

FLEX, which has a degree of freedom for selecting various industrial communication systems, not only realizes various design ideas, but also reduces labor and costs.

- Simple Wiring
- Labor Saving
- Time Saving
- Low Cost

Recommendation of System Configuration by FLEX for Each Interface

- Use of the Switch
- Use of the I/O Unit of PLC
- Use of the Touchscreen
- Use of the Serial Communication Unit of PLC
- Use of the Touch-Screen Panel Computer and the PC
- Use of the FA Network Unit

FLEX Solution

FLEX means simple control, simple connection, and lower costs.

Costs are reduced through parts selection and equipment design. The FLEX-compatible products recommended by Oriental Motor allow for total cost reduction, including host systems such as a PLC.

I/O Control

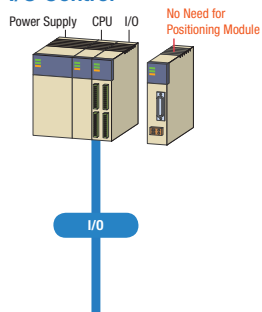

Control from a Touch Screen or Computer

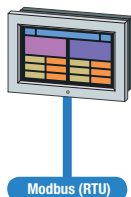

Serial Communication Control

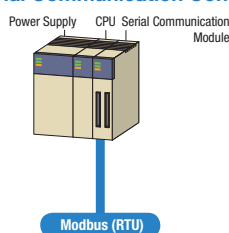

FA Network Control

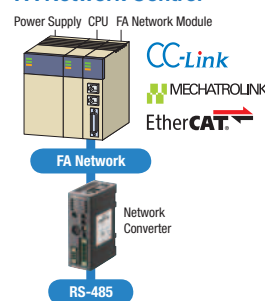

Network-Compatible Products Overview

Modbus (RTU)

EtherCAT, CC-Link, MECHATROLINK

Network Converters

Controller Overview

SCX11

Position Control

Stepper Motors

Stepper Motors **Q_{STEP}**
AR Series AZ Series



0.72° Stepper Motors
RKII Series



FLEX-Compatible Products

Linear & Rotary Actuators

Electric Linear Slides
EAS Series



Electric Cylinders
EAC Series



Hollow Rotary Actuators
DGII Series

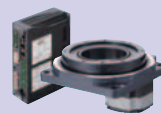

Speed Control

Brushless Motors

Brushless Motors
BLE Series



Control System Configuration for Each Built-in Controller Type

① Control via I/O

The positioning module (pulse generator) function is built into the driver, so an operation system using I/O can be configured by connecting directly to a switch box or PLC. A positioning module is not necessary on the PLC side, saving space and simplifying the system.

● Example of Using a Switch Box

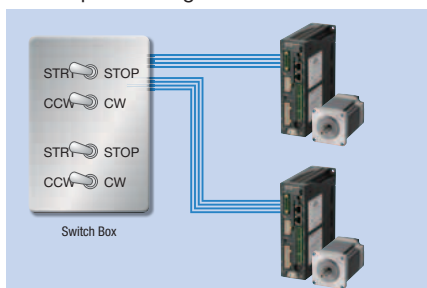

Operating data is set in the driver, and the motor can be started or stopped simply by connecting to the switch at hand. Control can be performed easily without using PLC.

Easy Control

Low-Cost Design

● Example of Using PLC

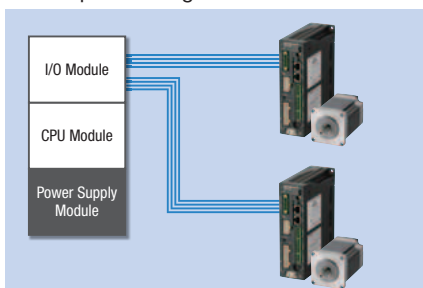

When using PLC, an operation system can be configured by connecting directly to an I/O module. A positioning module is not necessary on the PLC side, so space is saved and the system is simplified.

Easy Control

Low-Cost Design

Space Saving

● Example of Using PLC and a Touch Screen

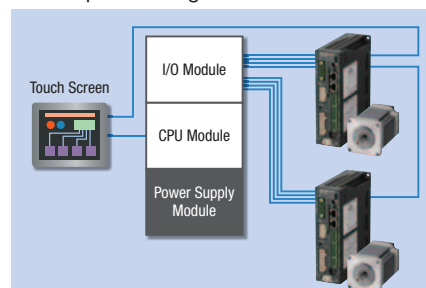

Normally, the motor is started and stopped with I/O. Changing the operating data settings and displaying the monitors and alarms are performed with the touch screen using Modbus (RTU) communication. When there is a lot of setup work, changes can be easily made on the touch screen, which reduces the burden of creating ladders.

Easy Control

Support for Small Lots of Multiple Products

② Control via Modbus (RTU)/RS-485 Communication

RS-485 communication can be used to set operating data and parameters, as well as input operation commands. Up to 31 drivers can be connected to 1 serial communication module. There is a function that enables multiple shafts to be started simultaneously. The Modbus (RTU) protocol is supported and can be used to connect to touch screen and computer.

Easy Control

Simple Wiring

Supports Brands of Serial Module

Motor Controlled by a Computer

Simplified System

③ Control via FA Network

By using a network converter (sold separately), CC-link, MECHATROLINK or EtherCAT communication are possible. All of these can be used to set operating data and parameters, as well as input operation commands.

Easy Control

Simple Wiring

Multi-Axis Control at Low Cost