

Orientalmotor

Become a Robot Master in Just 3 Steps

Robot Controller **MRC01**



The **MRC01** robot controller enables easy operation through a three-step process: initial setup, operation programming, and operation check.

It can be used to control **OVR** Series robots that use **α STEP** **AZ** Series / **AZ** Series equipped actuators.

Seamlessly Integrate Robots into Existing Systems

The **MRC01** connects directly to the host system via EtherNet/IP™, providing seamless control.

The **OVR** Series and custom-built robots can be easily integrated without requiring major changes to the existing control system.

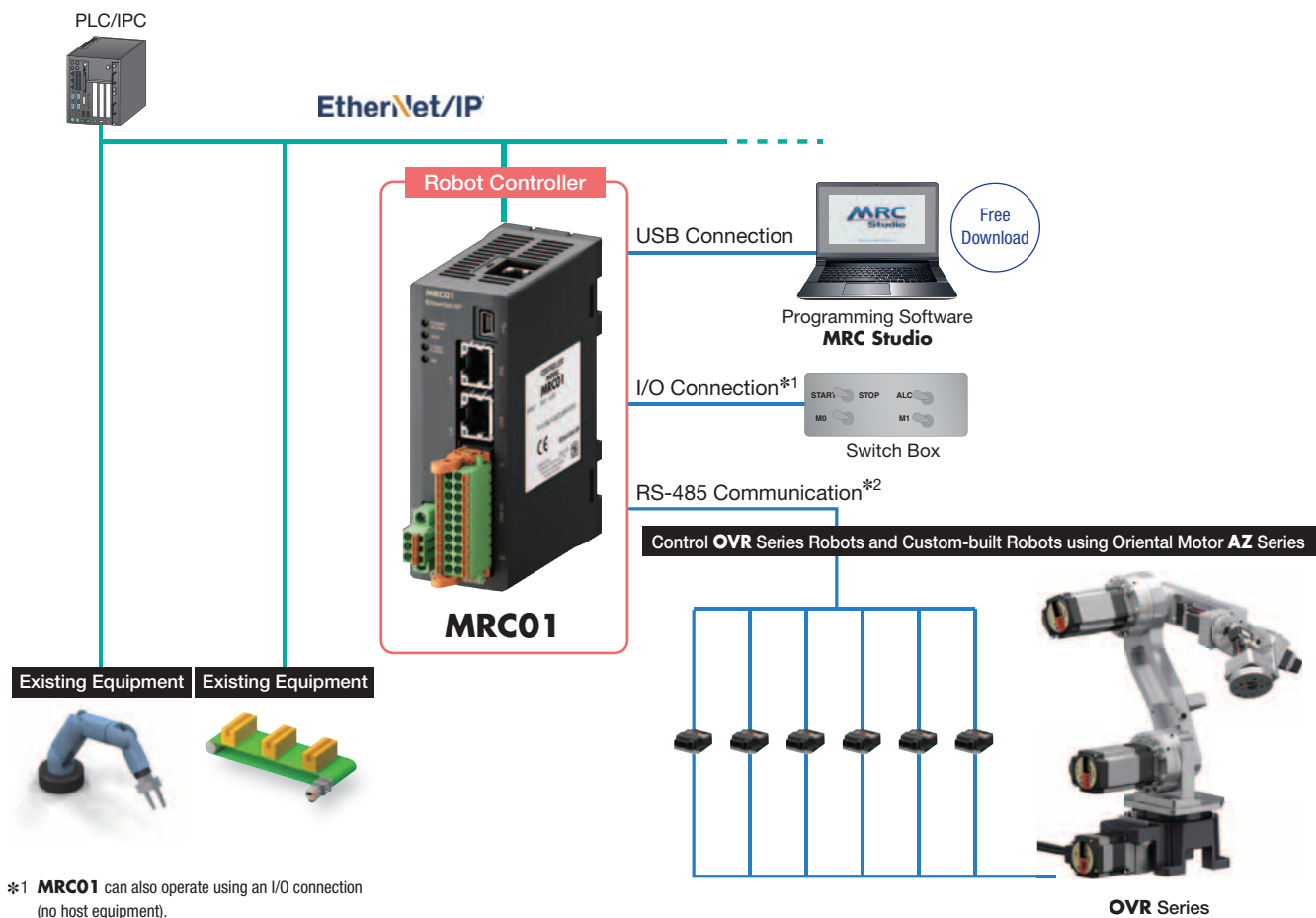

*1 **MRC01** can also operate using an I/O connection (no host equipment).

*2 Control is achieved using RS-485 communication between the **MRC01** and **AZ** Series drivers.

Vertically Articulated Robot Load Mass 1 kg (2.2 lb) Standard Cycle Time for Reciprocating Motion (Reference value)

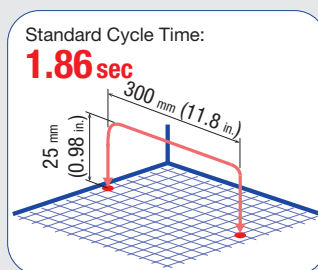
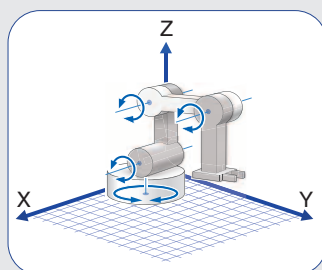

Easy Setup, Even for Beginners

The Programming Software “**MRC Studio**” simplifies the robot setup process, guiding users from the initial configuration to the final programming stages.

*The **MRC Studio** software and EDS files can be downloaded for free from the Oriental Motor website.

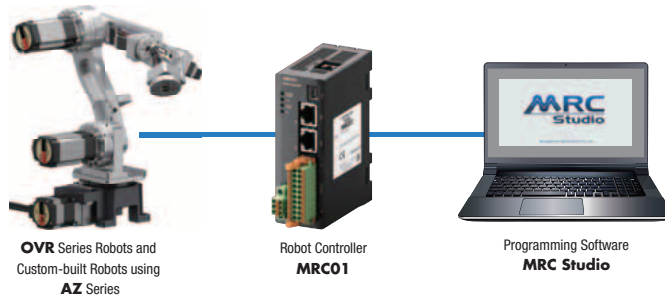

Step 1 Setup is Easy with Step by Step Guidance.

The setup wizard guides users through configuring the robot's initial settings, selecting the robot type, and inputting mechanism information. With the help of clear instructions and illustrations, even novice users can quickly set up the robot.

● Follow Set Up Steps



Proceed through initial setting of the robot by following the wizard menu.



● Input Dimensions (Arm Length, etc.) With the Help of the Illustration

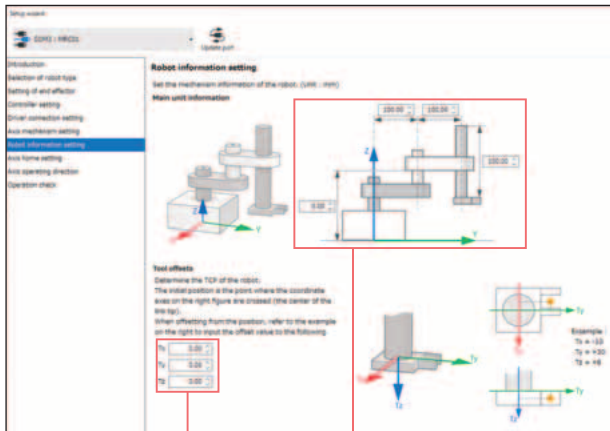

Dimensions are entered directly into the input spaces on the illustrations.

Videos demonstrating the products are available on our website.



● Select the Robot Type

Example

SCARA

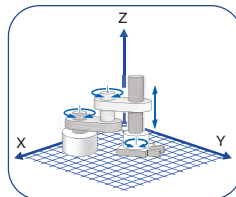

2 link elevating end axis + Rz axis

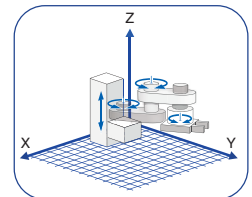

2 link elevating base axis + Rz axis

Articulated

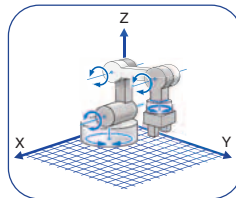

3 link base axis swivels + Rz axis

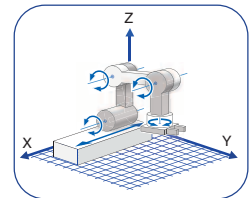

3 link linear motion of base axis + Rz axis

Perpendicular

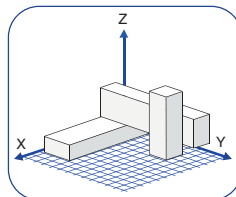

X-Y-Z

OV Series

This is a robot arm equipped with the **AZ Series**.

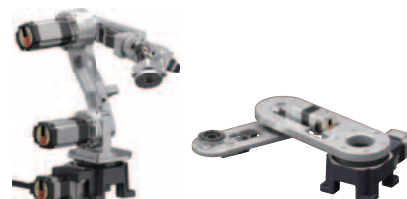

● Refer to the Oriental Motor website for details on supported robots.

Step 2 Say Goodbye to Ladder Logic! Select Items to Program Operation.

The program creation process utilizes a straightforward command selection format, allowing users to intuitively generate programs without specialized knowledge, such as ladder diagrams. The system supports a range of advanced motion control operations, including P-to-P, linear interpolation, circular interpolation, and arc motion, among others.

Operating data is executed directly from a host controller via EtherNet/IP.

● Drag and Drop the Required Commands

● Target Position and Speed Setting

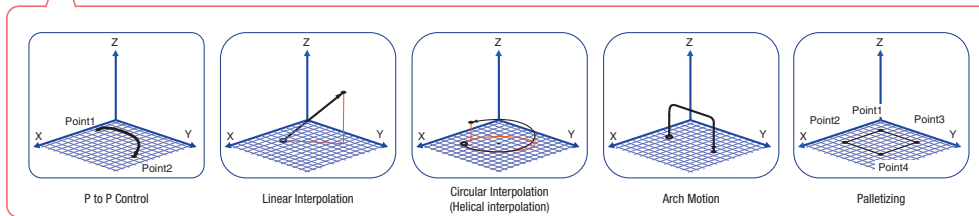
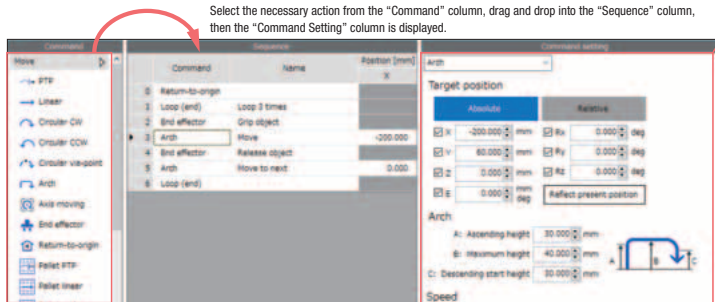

Step 3 Check Operation and Verify Programming Using the Simulator.

The program running time can be displayed and the contents of the program can be verified while taking into account the robot's moving ion range, etc.

3D graphics can be used to check operation, without the need to physically move the robot itself.

*There is a possibility of differences between the simulation and the actual operation.

*Communication with the **MRC01** is required for the simulation.

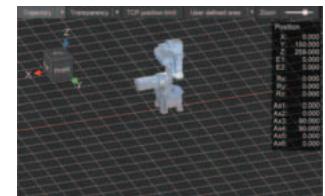
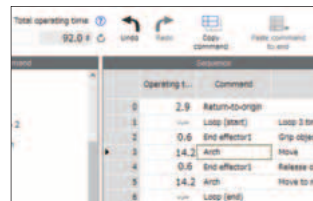

MRC Studio Simulator (Free). Robot operation can be checked during the pre-purchase investigation stage.

MRC Studio Simulator is a free software program that allows you to simulate actual movements without the robot itself or **MRC01**. Operation programs created in **MRC Studio Simulator** can be used as-is when the actual robot is installed.

● Differences between **MRC Studio Simulator** and **MRC Studio**

● Available on our website

Item	MRC Studio Simulator	MRC Studio (Product version)
Communication with robot controller MRC01	—	○
Setup	△ Items that communicate with the robot controller MRC01 or driver cannot be set.	○
Save setting data files to PC	○	○
Opening files	○ Can open .mrcxt files. Sample setting files are also available.	○ Can open .mrcx files.
Importing data files created in MRC Studio Simulator	—	○*
Teaching	○	○
Creating operation programs	○	○
Test operation	○	○
Setting parameters	△ Some parameters cannot be set. For details, please check "Show Method of Use" in the MRC Studio Simulator "Help" section.	○
Monitor	△ Information on signal systems that require connection to external devices cannot be monitored.	○



*The **MRC Studio Simulator** does not consider the loading conditions of each axis, which may cause differences in actual motion.

When operating the actual device for the first time, a lower operating speed is recommended.

The 2D Camera Integration Function Allows for the Automation of More Advanced Work

Configuration of a Robot Vision System Using 2D Cameras

The robot controller **MRC01** is equipped with useful functions for operating the robot using load position and angle information acquired by the camera.

- Acquire Load Position and Angle Information Using the Camera

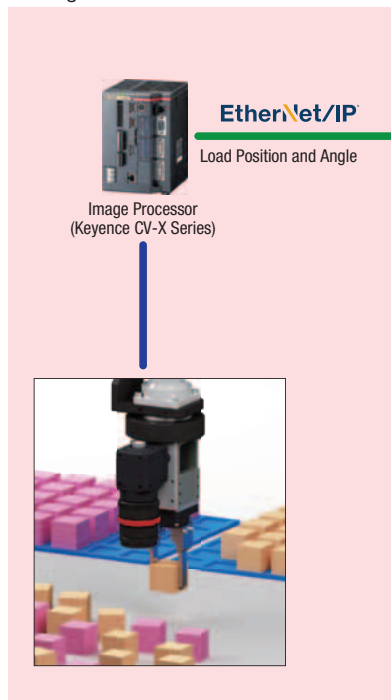

- Convert to Robot Coordinates and Operate

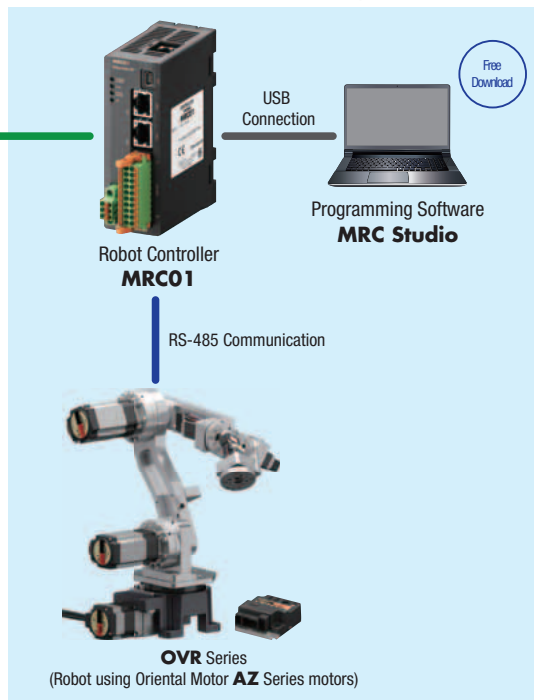

- About Supported Image Processors and PLC Models

The above configuration diagram is a connection example for the CV-X series from Keyence Corporation. Information about other compatible models will be posted to the Oriental Motor website as it becomes available.

- About Calibration

In order to integrate the 2D camera, **MRC Studio** is used to perform the calibration in advance. The settings can be easily configured by simply following the on-screen instructions while looking at the illustrations, allowing for a reduction in the work hours necessary for correction. (Up to 2 cameras can be calibrated.)

Application Example

There are many automated operations that can be achieved by integrating and linking 2D cameras, such as load position detection and dimensional/external inspections. Representative examples are shown here.

- ◇ Position Correction

Alignment of complicated workpieces (Fixed camera system)

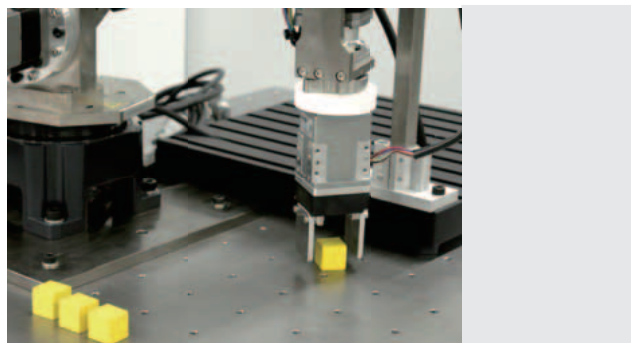

- ◇ Color Discrimination

Differentiates workpieces of different colors (Hand-eye system)



Product Line

Product Name
MRC01

Included

- CN1 Connector (1 pc.)
- CN4 Connector (1 pc.)

Specifications

Basic Specifications



Power Supply	Input Voltage	24 VDC ±10%
	Input Current	0.2 A
Interface	Field Network	EtherNet/IP
	Control Input	8 points, Photocoupler
	Control Output	8 points, Photocoupler and Open-Collector
RS-485 Communication Specification		Modbus RTU EIA-485 compliance, Straight cable Shielded twisted-pair wire (TIA/EIA-568B CAT5e or greater recommended) is used up to a total extension length of 50 m (164 ft.).*1
USB Connector	Specifications	USB 2.0 (Full-Speed)
	Cable	Length: 3 m (9.8 ft.) max. Type: A to mini B
Setting Tool		Programming Software MRC Studio
Number of Control Axes		8 axes max.*2
Robot Model		Horizontal Articulated (2-link, 3-link), Vertical Articulated (3-axis to 6-axis) Palletizer (1-link mechanism, 2-link mechanism), Parallel Link, Polar/Cylindrical Coordinates, Orthogonal (2-axis, 3-axis), Orthogonal-Horizontal Gantry (2-axis, 3-axis)
Drive Command		P to P, Linear Interpolation, Circular Interpolation, Arc Interpolation, Palette (P to P, Line, Arc)
Monitor		Robot Graphic, Alarm, Information, etc.

*1 If noise generated by the motor cable or power supply cable causes a problem due to wiring and installation, try shielding the cables or insert ferrite cores.

*2 Only one robot can be controlled by **MRC01**.

The number of control axes depends on the robot model. For example, if the robot model is horizontal multi-joint (2-links, up and down of tip axis) and also controls the end effector (1 axis), the number of control axes will be 4 axes.

EtherNet/IP Specifications

Protocol		EtherNet/IP (CT17 compliance)
Vendor ID		187: Oriental Motor Company
Device Type		43: Generic Device
Transmission Rate		10/100 Mbps (Auto-negotiation)
Communication Mode		Full-duplex/Half-duplex (Auto-negotiation)
Cable Specifications		Shielded Twisted-pair (STP) Cable Straight/Cross, Category 5e or greater is recommended [Total extension length: 50 m (164 ft.) max.]
Occupied Byte	Output (Scanner → MRC01)	2 to 228 bites
	Input (MRC01 → Scanner)	2 to 228 bites
Implicit Communication	Number of Supported Connections	2
	Connection Type	Exclusive Owner, Input Only
	Communication Cycle	10 to 3,200 ms
	Connection Type (Scanner → MRC01)	Point-to-Point
	Connection Type (MRC01 → Scanner)	Point-to-Point, Multicast
	Data Reflection Trigger	Cyclic
IP Address Setting Method		Parameter, DHCP
Supported Topology		Star, Linear, Ring (Device Level Ring)

General Specifications

Degree of Protection	IP10
Operating Environment	Ambient Temperature: 0 to +55°C (+32 to +131°F) (Non-freezing)
	Humidity: 85% or less (Non-condensing)
	Altitude: Max. of 1000 m (3300 ft.) above sea level
	Atmosphere: No corrosive gases or dust. The product should not be exposed to water or oil.
Storage Conditions Transportation Conditions	Ambient Temperature: -25 to +70°C (-13 to +158°F) (Non-freezing)
	Humidity: 85% or less (Non-condensing)
	Altitude: Max. of 3000 m (10000 ft.) above sea level
	Atmosphere: No corrosive gases or dust. The product should not be exposed to water or oil.
Insulation Resistance	The measured value is 100 MΩ or more when a 500 VDC megger is applied between the following locations: · FG Terminal – Power Supply Terminal

Note

- When measuring insulation resistance or performing dielectric voltage withstanding tests, disconnect the controller and the motor/actuator.

Standard Cycle Time (Reference Value)

The standard cycle time (reference value) is the time required for reciprocating operation of 25 mm (0.98 in.) vertically and 300 mm (11.8 in.) horizontally with a load mass of 1 kg (2.2 lb.).

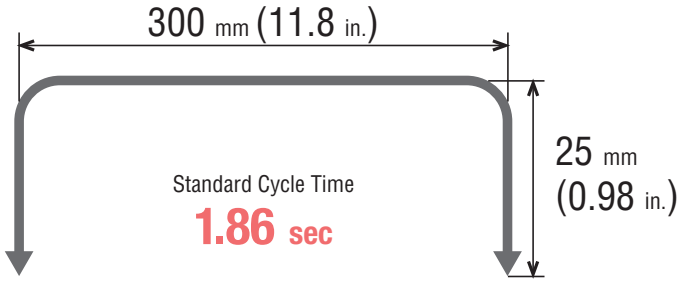

Note

The standard cycle time (reference value) is the data obtained by our in-house robot measured under the operating conditions where the torque of each axis is sufficient for the load mass. Cycle time depends on your operating conditions.

Positioning Distance – Positioning Time (Reference Value)

The positioning time (reference) can be checked from the positioning distance. The positioning time depends on the load mass.

Horizontal Multi-Joint Robot (2-Links, Elevating Base Axis)

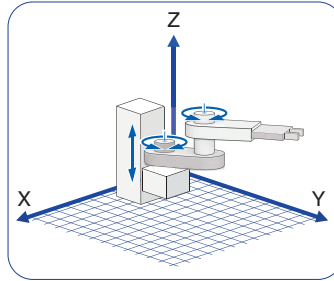
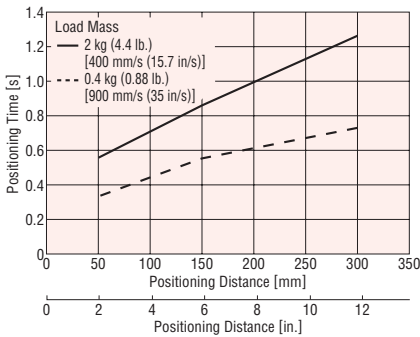

Vertical Multi-Joint Robot (3-Links, Turning Base Axis)

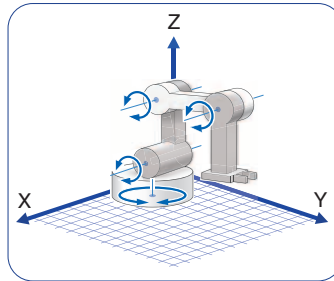
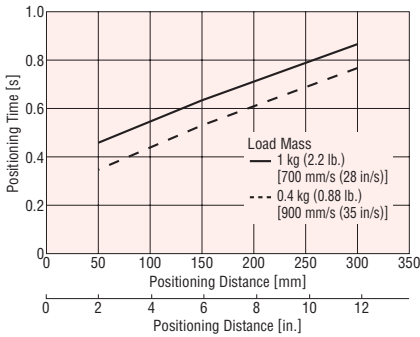

Dimensions Unit: mm (in.) 2D & 3D CAD

Product Name	Mass kg (lb.)	2D CAD
MRC01	0.12 (0.26)	B1537

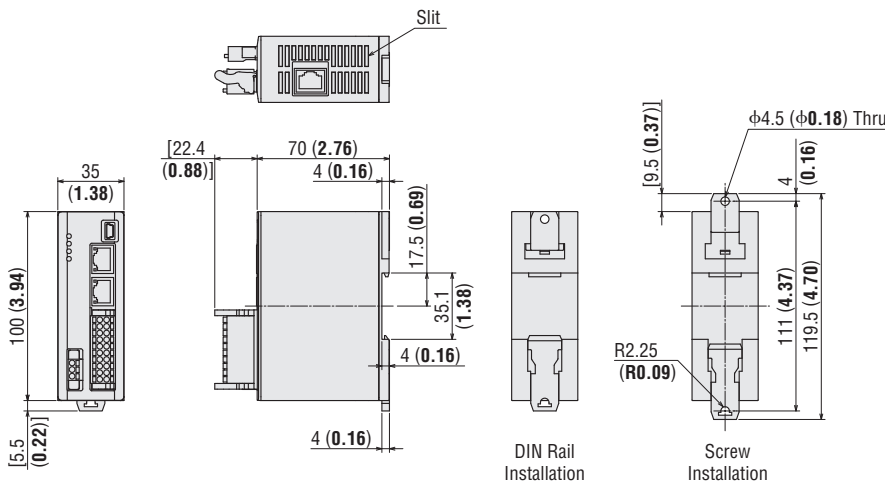

- Included
- Power Supply Connector (CN1)
Connector: FMC1,5/3-STF3,5
(Phoenix Contact)
- I/O Signal Connector (CN4)
Connector: DFMC1,5/10-ST-3,5-LR
(Phoenix Contact)

Cables

RS-485 Communication Cables

These cables are used to connect **MRC01** and **AZ** Series driver.

Product Line

Product Name	Length L [m (ft.)]	Applicable Driver
CC001-RS4	0.1 (0.33)	Built-in Controller Type DC Input Driver
CC002-RS4	0.25 (0.83)	Built-in Controller Type AC Input Driver Built-in Controller Type DC Input Driver
CC02FLT6	2 (6.6)	Compact Driver RS-485 Communication Type
CC05FLT6	5 (16.4)	



Dimensions Unit: mm (in.)

CC001-RS4, CC002-RS4

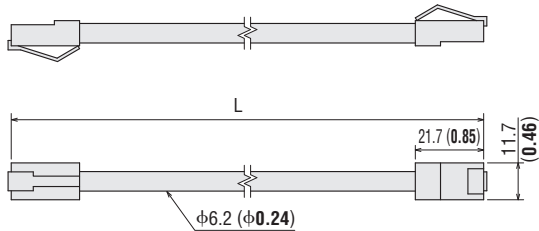

CC02FLT6, CC05FLT6

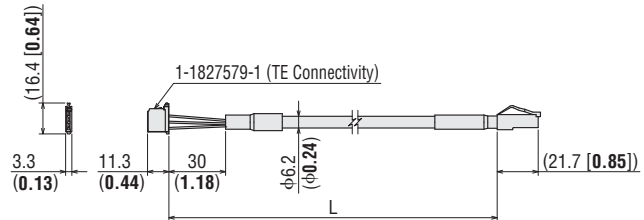

I/O Signal Cables General-Purpose Type

- Shielded cables
- Loose wires at both ends
- Easy shield grounding with round ground wire terminals
- The number of lead wire cores can be selected to match the functions being used



Product Line

Product Name	Length L [m (ft.)]	Number of Lead Wire Cores	Outer Diameter D [mm (in.)]	AWG
CC06D005B-1	0.5 (1.64)	6	φ5.4 (φ0.21)	24
CC06D010B-1	1 (3.3)			
CC06D015B-1	1.5 (4.9)			
CC06D020B-1	2 (6.6)	10	φ6.7 (φ0.26)	
CC10D005B-1	0.5 (1.64)			
CC10D010B-1	1 (3.3)			
CC10D015B-1	1.5 (4.9)	12	φ7.5 (φ0.30)	
CC10D020B-1	2 (6.6)			
CC12D005B-1	0.5 (1.64)			
CC12D010B-1	1 (3.3)	16	φ7.5 (φ0.30)	
CC12D015B-1	1.5 (4.9)			
CC12D020B-1	2 (6.6)			
CC16D005B-1	0.5 (1.64)	16	φ7.5 (φ0.30)	
CC16D010B-1	1 (3.3)			
CC16D015B-1	1.5 (4.9)			
CC16D020B-1	2 (6.6)			

Dimensions Unit: mm (in.)

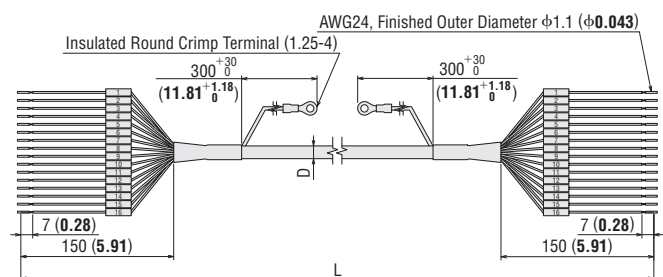

● The figure depicts 16 core wires.

DC Power Supply Cables

These cables are used to connect **MRC01** and the DC power supply.

Product Line

Product Name	Length L [m (ft.)]
CC02D005-3	0.5 (1.64)
CC02D010-3	1 (3.3)
CC02D015-3	1.5 (4.9)
CC02D020-3	2 (6.6)
CC02D050-3	5 (16.4)



Dimensions Unit: mm (in.)

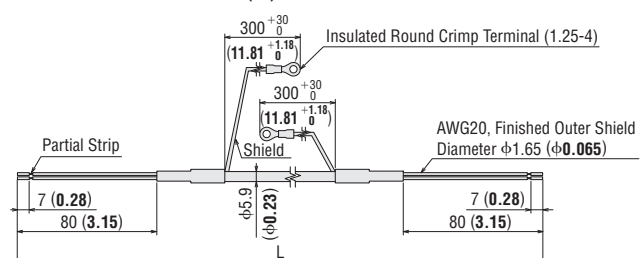

■ Applicable Products

This controller can connect to the following **AZ** Series drivers. It can also be connected to an **AZ** Series-equipped Linear & Rotary Actuators.

AZ Series Drivers

● Built-in Controller Type

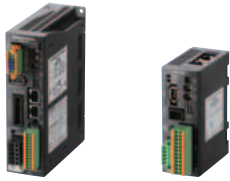

Single-Phase 100-120 VAC, 24/48 VDC
Single-Phase/Three-Phase
200-240 VAC

● mini Driver RS-485 Communication Type



24/48 VDC

AZ Series Motors, AZ Series-Equipped Linear & Rotary Actuators

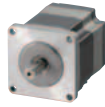

Motors



Hollow Rotary Actuators
DGI Series



Compact Linear Actuators
DR Series
DRS2 Series



Electric Linear Slides
EZS Series
EAS Series



Electric Cylinders
EAC Series



Lack and Pinion Systems
L Series



Electric Gripper
EH Series

OVR Series

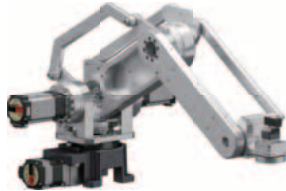

Articulated Robot Arm (4-axis)



Articulated Robot Arm (5-axis)



Articulated Robot Arm (6-axis)



SCARA Robot Arm

Specifications are subject to change without notice. This catalog was published in August 2024.

ORIENTAL MOTOR U.S.A. CORP.

Western Sales and Customer Service Center

Tel: (310) 715-3301 Fax: (310) 225-2594

Los Angeles

Tel: (310) 715-3301

San Jose

Tel: (408) 392-9735

Midwest Sales and Customer Service Center

Tel: (847) 871-5900 Fax: (847) 472-2623

Chicago

Tel: (847) 871-5900

Toronto

Tel: (905) 502-5333

Eastern Sales and Customer Service Center

Tel: (781) 848-2426 Fax: (781) 848-2617

Boston

Tel: (781) 848-2426

New York

Tel: (973) 359-1100

Technical Support

Tel: (800) 468-3982 / 8:30 A.M. to 5:00 P.M., P.S.T. (M-F)
7:30 A.M. to 5:00 P.M., C.S.T. (M-F)

E-mail: techsupport@orientalmotor.com

Obtain Specifications, Online Training
and Purchase Products at:
www.orientalmotor.com