

## Clutch and Brake Motors

# C·B Motors

This compact precision motor is equipped with an internal clutch and brake for use with a gearhead. The combination makes it the ideal motor for uses involving frequent START/STOP operation, positioning, indexing, jogging and incremental feeding.



Gearhead shown in the photograph is sold separately.



### Product Number Code

**CB I 5 40 - 7 0 1W U**

**U:** With capacitor for 110V/115V

**1W:** Single-Phase 110V/115 V

**Clutch Brake Type**  
**O:** Excitation type

**Motor Shaft Type**  
**7:** GC- type pinion shaft  
**8:** GCH- type pinion shaft

**Output Power**  
**40:** 40W  
**60:** 60W  
**90:** 90W

**Motor Frame Size**  
**5:** 3.54 in.sq. (90mm sq.)

**Motor Type**  
**I:** Induction motor

**Series:** Clutch and Brake Motor

**Note :** The "U" at the end of the part number indicate that the unit includes a capacitor. This letter is not listed on the motor nameplate.

### Features

#### ● Suitable for high-frequency operation

The high-frequency and high-response clutch and brake enables frequent starting and stopping.

#### ● Compact and easy to handle

The compact design simplifies handling and enables the drive unit of the machine to be mounted into a small area.

#### ● Highly reliable gearhead employed

GC- type and GCH- type gearheads are specifically designed for C·B motors and boast excellent impact resistance, greater strength and high reliability.

#### ● Quick response time

The C·B motor is designed so that it runs continuously. This gives the advantage of a quicker response time and a higher torque in order to move the load.

The output shaft is controlled through the use of the clutch and brake mechanism. The load is stopped by disengaging the clutch and applying the brake. The motor is always affected by the rotor inertia. However, with a clutch and brake unit, the load is not affected by the rotor inertia.

For these reasons, C·B motors boast superior response over other AC standard motors, starting and stopping in considerably less time.

To meet high-frequency, starting and stopping applications, Oriental Motor uses an induction motor for continuous duty. An induction motor is best suited for uni-directional movements. The C·B motor is not suitable for frequent bi-directional starting and stopping motion.

### Construction

Flexible Coupling  
(Sold separately)  
Page A-260



Gearhead  
(Sold separately)

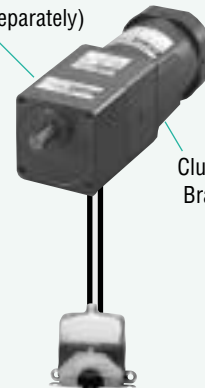

Clutch and Brake Motor

Capacitor and capacitor cap.  
(Included)

## Product Lines

To select the appropriate **C-B** motor, consult the output power characteristics on page A-198.



Model Frame Size	Output Power		Voltage VAC	Model	Motor Model	Gearhead Model
	HP	W				
3.54 in.sq. (90 mm sq.)	1/18.5	40	Single-Phase 100/115	<b>CBI540-701WU</b>	5IK40GN-AW-CB1	<b>5GC</b> □ <b>KA</b> (Sold separately)
	1/12.5	60	Single-Phase 100/115	<b>CBI560-801WU</b>	5IK60GU-AW-CB1	<b>5GCH</b> □ <b>KA</b> (Sold separately)
	1/8	90	Single-Phase 100/115	<b>CBI590-801WU</b>	5IK90GU-AW-CB1	

### Note:

- The **GC-** and **GCH-** type gearheads are designed specifically for use with the **C-B** motor. Other type gearheads may not be connected.
- The motors contain a built-in thermal protector. When a motor overheats for any reason, the thermal protector is opened and the motor stops. When the motor temperature drops, the thermal protector closes and the motor restarts. Be sure to turn the motor off before inspecting.
- The clutch and brake units is not sold separately from the motor.
- The "**U**" at the end of the part number indicate that the unit includes a capacitor. This letter is not listed on the motor nameplate.

## General Motor Specifications

(After rated motor operation under normal ambient temperature and humidity.)

Item	Specifications
Insulation Resistance	100MΩ or more when 500V DC is applied between the windings and the frame.
Dielectric Strength	Sufficient to withstand 1.5kV at 50 and 60Hz applied between the windings and the frame.
Temperature Rise	144°F (80°C) or less measured by the resistance change method after rated motor operation with a gearhead.
Insulation Class	Class B 266°F(130°C)
Overheat Protection	All models have built-in thermal protectors (Automatic return type) Operating temperature, open: 266°F±41°F (130°C±5°C) close: 179.6°F±59°F (82°C±15°C)
Ambient Temperature Range	14°F~104°F (-10°C~+40°C)
Ambient Humidity	85% maximum (noncondensing)

## Clutch/Brake Specifications

Model Frame Size	Clutch / Brake	Holding Brake Torque		Voltage VDC	Input W (at 68°F (20°C))	Cycle Rates time/minute
		oz-in	mN·m			
3.54 in.sq. (90 mm sq.)	Clutch	208	1500	24	8.4	100
	Brake	208	1500	24	6.2	

## Safety Standards and CE Marking (Motor only)

Standards	Certification Body	Standards File No.	CE Marking
UL1004 UL547 CAN/CSA-C22.2 No.100 CAN/CSA-C22.2 No.77	UL	E64197	Low Voltage Directives
EN60950	VDE	6751ÜG	
EN60034-1 EN60034-5 IEC60034-11	Conform to EN/IEC Standards. (EN/IEC certifications are scheduled.)		

- For installation conditions for EN/IEC standards, see Page D-2.
- Motors are recognized by UL and certified by VDE. The clutch and brake unit is not UL recognized. Recognized name and certified name are motor model name.

## ■ Structure and Operations of C-B Motor



The photograph above shows the structure of the clutch and brake unit. When no 24V DC is applied to either the clutch coil or brake coil, the output shaft can be rotated by hand.

### ●Run

When DC 24V is applied to the clutch coil, the armature of the clutch coil is drawn against the clutch plate, transmitting motor rotation to the output shaft.

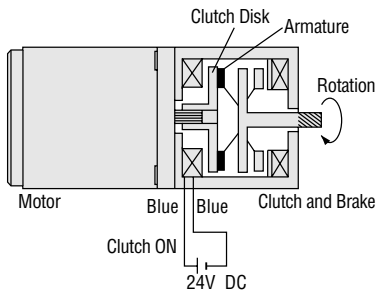

### ●Stop, Load Holding

By removing the DC 24V from the clutch coil, and, after a certain time lag, applying DC 24V to the brake coil, the output shaft will come to a stop. During braking output shaft is released from the motor shaft, so the shaft may be stopped without being influenced by motor inertia. The motor continues to rotate.

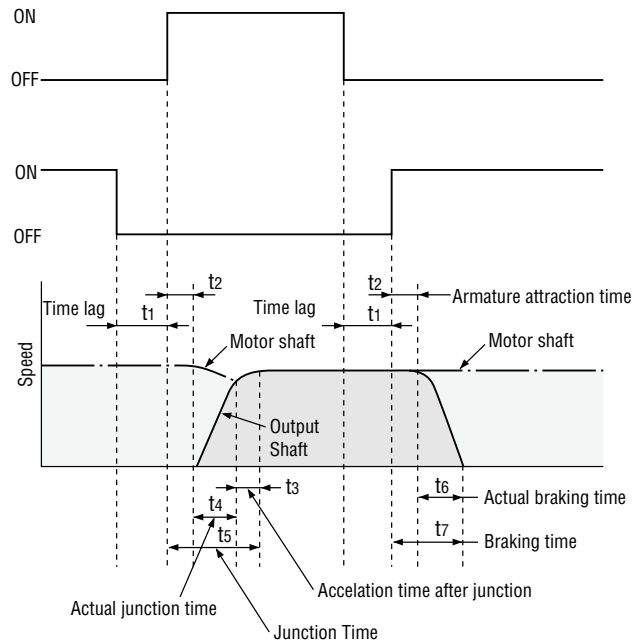
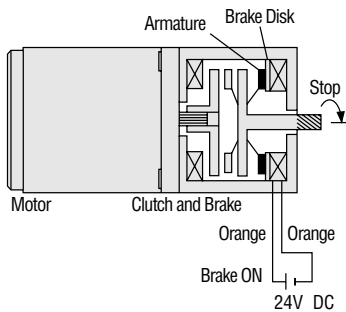

The figure above shows the relationship between the action of the motor shaft and output shaft and the state of excitation of the clutch and brake coils.

### ●Operation

When operation is shifted from holding the load to moving the load, there is a lag of 20 msec. between the time the brake is released and the time voltage is applied to the clutch. This is to prevent the clutch and brake from engaging at the same time. The time required for the clutch/brake output shaft to reach a constant speed after voltage is applied to the clutch is called the junction time ( $t_5$ ) and is calculated by adding the following elements:

#### ① Armature attraction time $t_2$

The time from application of voltage to the clutch coil until contact of the armature with the clutch plate.

#### ② Actual junction time $t_4$

The time required after the armature comes in contact with the clutch for the clutch/brake output shaft, accelerated by dynamic friction torque, to engage completely with the motor shaft.

#### ③ Acceleration time after junction $t_3$

The time needed to accelerate back to the required speed if load is applied suddenly to the motor during actual junction time above, causing a temporary drop in speed.

## ● Braking

When operation is shifted from rotation to stopping or holding of a load, a time lag of about 20 msec. is necessary after the clutch is disengaged before voltage is applied to the brake coil.

The time required after applying voltage to the brake for the clutch/brake output shaft to actually stop is called the braking time ( $t_7$ ), and is obtained by adding the following elements:

### ① Armature attraction time $t_2$

The time from the application of voltage to the clutch coil until contact of the armature with the brake plate.

### ② Actual braking time $t_6$

The time from the moment the armature comes in contact with the brake plate until the moment the output shaft comes to a complete stop.

The following graphs indicate examples of junction and braking characteristics.

Junction Characteristics **CBI590-801WU**

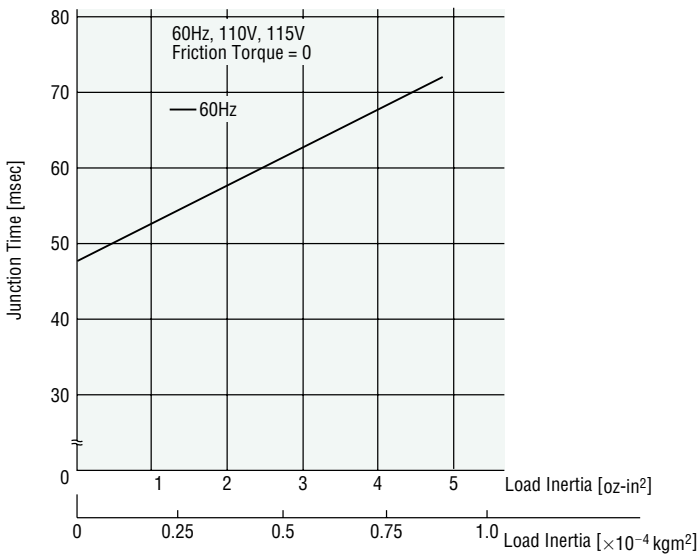

Braking Characteristics **CBI590-801WU**

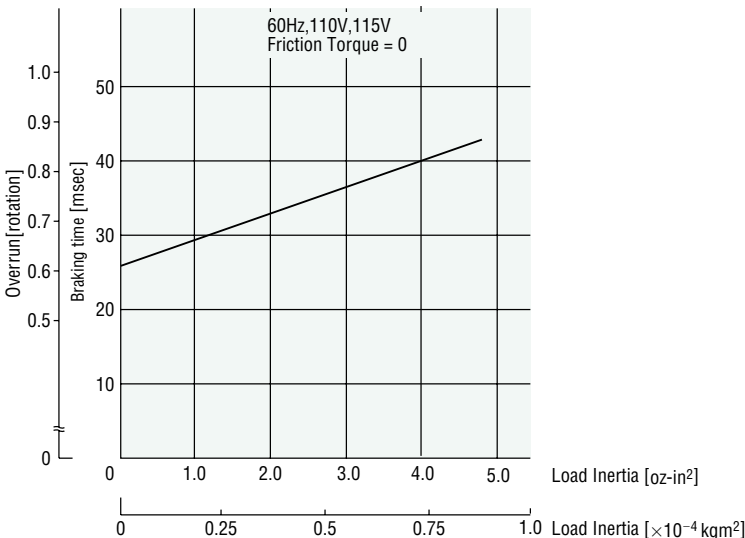

## ■ GC- and GCH- Type Gearhead for C-B Motors

The **GC-** and **GCH-** type gearheads have been specially designed for use with the **C-B** motor. Although they look much the same as the **GN-** and **GU-** type gearheads, their gearing specifications differ, making them incompatible. Never attempt to connect **GC-** or **GCH-** type gearheads to **GN-** or **GU-** type gearing motors, or to combine **GN-** or **GU-** type gearheads with a **C-B** motor:

Permissible overhung load and permissible thrust load for **GC-** and **GCH-** type gearheads may not exceed the limits given in the table below.

unit = lb (N)

Model	Gear Ratio	Permissible Overhung Load		Permissible Thrust Load
		0.4 in. (10mm) from shaft end	0.8 in. (20mm) from shaft end	
<b>5GC</b> □ <b>KA</b>	<b>3.6~18</b>	55.1(250)	77.2(350)	22.0(100)
	<b>30~180</b>	66.1(300)	99.2(450)	
<b>5GCH</b> □ <b>KA</b>	<b>3.6~9</b>	88.2(400)	110(500)	33.1(150)
	<b>15~18</b>	99.2(450)	132(600)	
	<b>30~180</b>	110(500)	154(700)	

● Enter the gear ratio in the box (□) within the model number.

## ■ Note

- When using **C-B** motors, a DC 24V power supply for the clutch and brake is required in addition to the motor power supply.
- Transformer capacity on the DC power supply should be at least 1.3 times the rated power consumption of the clutch and brake. (See page A-195.)
- Do not try to activate clutch and brake simultaneously. When shifting from clutch to brake or vice versa, leave a time lag of at least 20 msec.

## Output Power Characteristics

The most appropriate **C-B** motor type may be determined by load torque and load inertia requirements of the motor and gearhead using the output selection charts below.

The curves represent the relationship between load torque and load inertia for a minimum of two million starts and stops. The motor should be operated inside the limits of the load torque load inertia curves given.

Find the clutch and brake motor best suited for your application as follows:

- ① Determine the maximum load torque required at the gearhead output shaft.
- ② Calculate the reflected load inertia effective at the gearhead output shaft.
- ③ Plot the values found in ① and ② into the graph of the applicable speed. The motor model whose characteristic curve is the closest and above the point you entered is the most suitable motor for your purpose.

### Speed at Output Shaft: 500r/min Gear ratio 3.6:1 at 60 Hz

[ $\times 10^{-4} \text{kgm}^2$ ] [lb-in<sup>2</sup>]

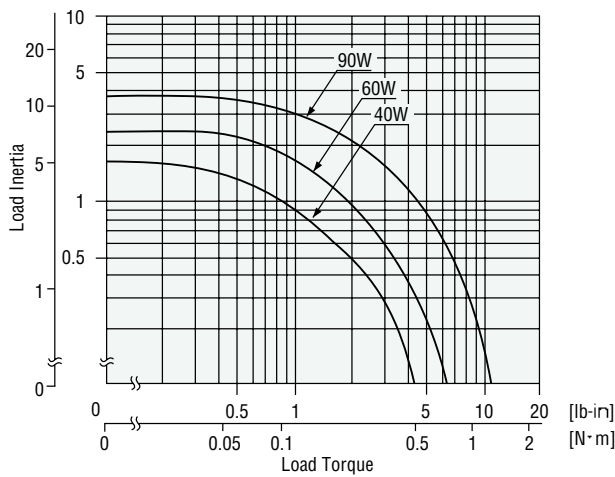

### Speed at Output Shaft: 200r/min Gear ratio 9:1 at 60 Hz

[ $\times 10^{-4} \text{kgm}^2$ ] [lb-in<sup>2</sup>]

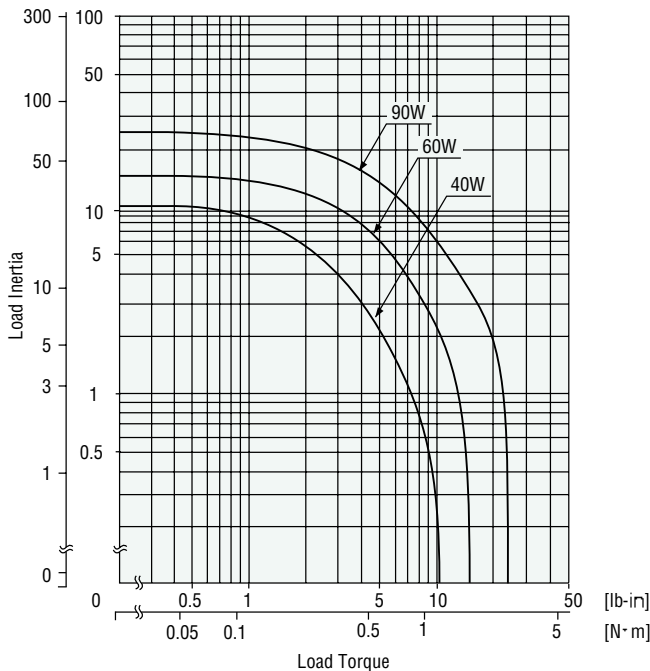

## Selection Example

- Required Speed: 300r/min
- Load Torque: 2 lb-in
- Load Inertia: 3 lb-in<sup>2</sup>

As an example, the value corresponding to these operating requirements have been marked in the application graph for 300r/min.

- The speed indicated is calculated by dividing the motor synchronous speed (1800r/min at 60Hz) by the speed reduction ratio. Note that depending on the load, the actual speed may be 2~20% lower than indicated in the graph.

### Speed at Output Shaft: 300r/min Gear ratio 6:1 at 60 Hz

[ $\times 10^{-4} \text{kgm}^2$ ] [lb-in<sup>2</sup>]

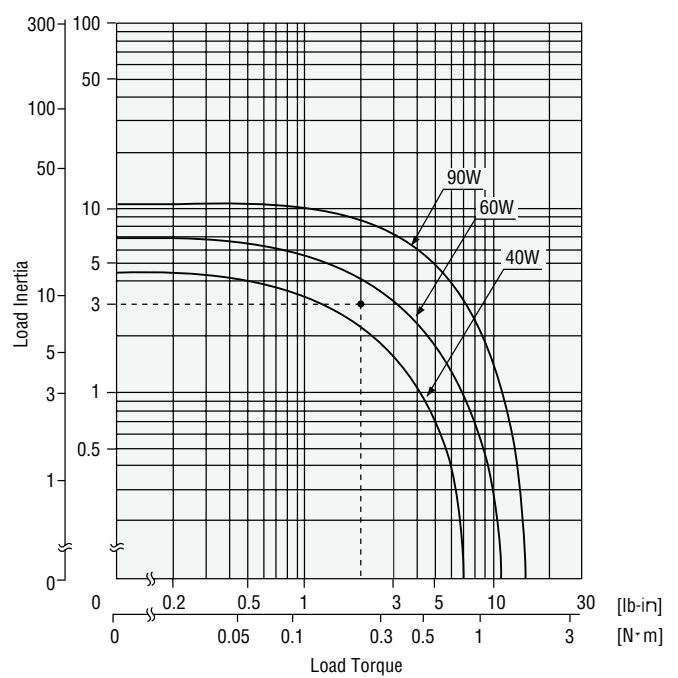

### Speed at Output Shaft: 120r/min Gear ratio 15:1 at 60 Hz

[ $\times 10^{-4} \text{kgm}^2$ ] [lb-in<sup>2</sup>]

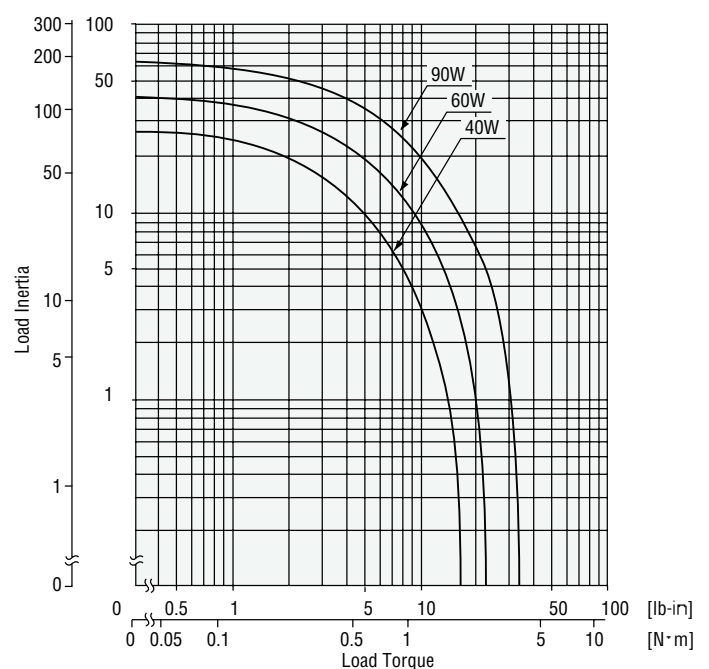

● Speed at Output Shaft: 100r/min  
Gear ratio 18:1 at 60 Hz

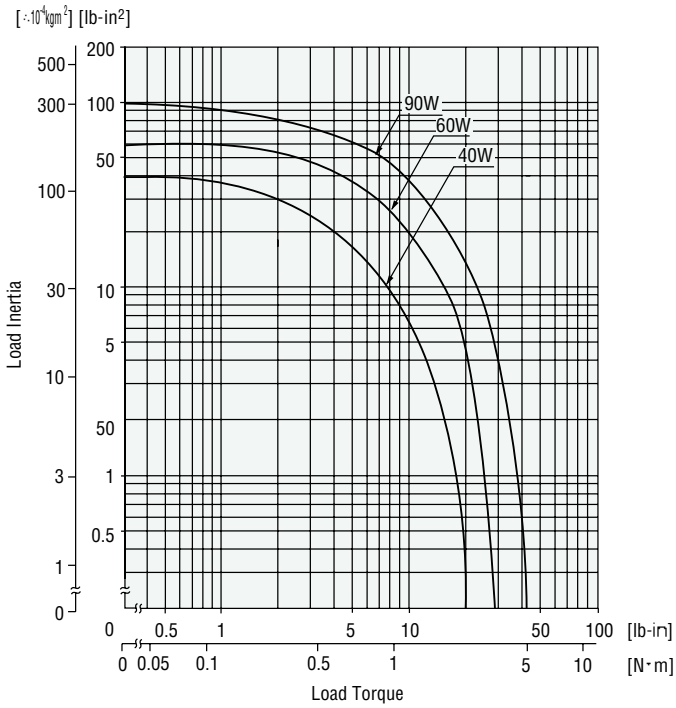

● Speed at Output Shaft: 60r/min  
Gear ratio 30:1 at 60 Hz

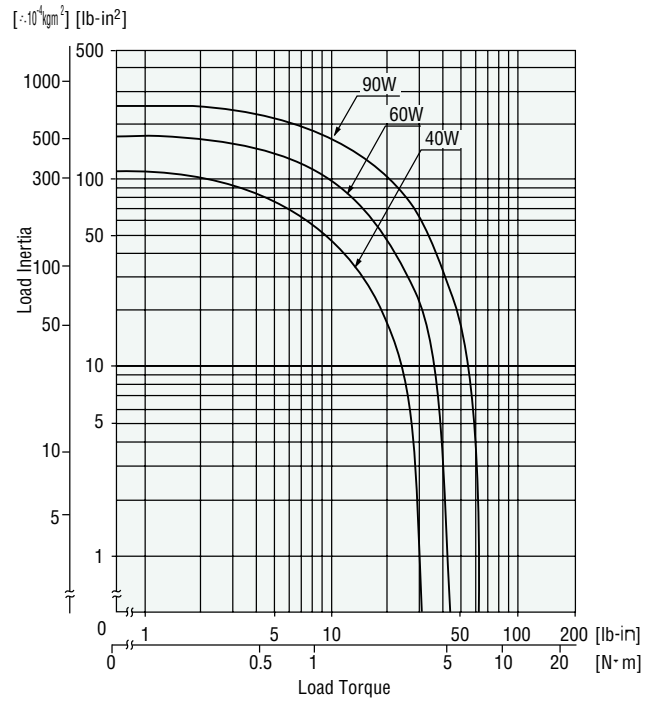

● Speed at Output Shaft: 50r/min  
Gear ratio 36:1 at 60 Hz

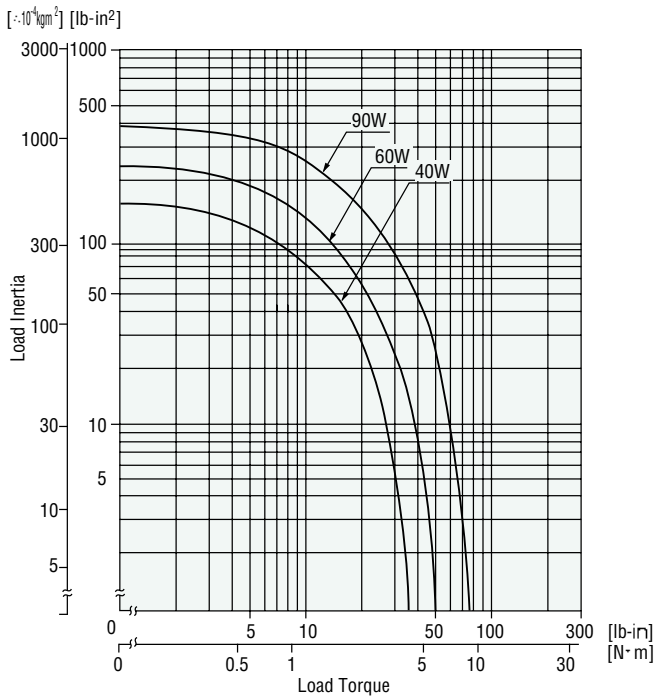

● Speed at Output Shaft: 30r/min or slower  
Gear ratio 60:1 or greater at 60 Hz

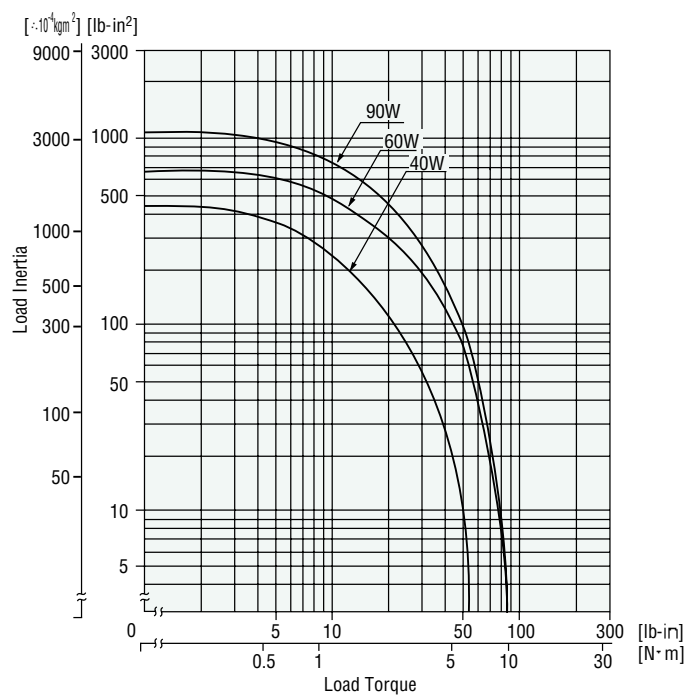

**Note:** When using a **C.B** motor at an output shaft speed of less than 30r/min (when using with gearheads of speed reduction ratios greater than 60:1 at 60Hz), use the output selection chart entitled "30r/min or slower."

## C·B Motors

**40**W(1/18.5HP) • **60**W(1/12.5HP) • **90**W(1/8HP)



### Motor Specifications-Continuous Rating

The gearhead is sold separately. Always use **GC-**, **GCH-** type gearhead with **C·B** unit.



Model	Output Power		Voltage V	Frequency Hz	Current A	Rated Speed r/min	Capacitor μ F
	HP	W					
<b>CBI540-701WU</b>	1/18.5	40	Single-Phase 110V	60	0.68	1500	9.0
			Single-Phase 115V		0.67		
<b>CBI560-801WU</b>	1/12.5	60	Single-Phase 110V	60	1.09	1450	18.0
			Single-Phase 115V		1.10		
<b>CBI590-801WU</b>	1/8	90	Single-Phase 110V	60	1.45	1500	20.0
			Single-Phase 115V		1.44		

### Speed Range

Gear Ratio	3.6	6	9	15	18	30	36	60	90	120	180
60Hz	500	300	200	120	100	60	50	30	20	15	10

The speed is calculated by dividing the motor's synchronous speed (60 Hz: 1800 r/min) by the gear ratio. The actual loaded speed is 2 ~ 20% less than the displayed value, depending on the amount of the load.

### Wiring Diagrams

The direction of motor rotation is as viewed from the shaft end of the motor.

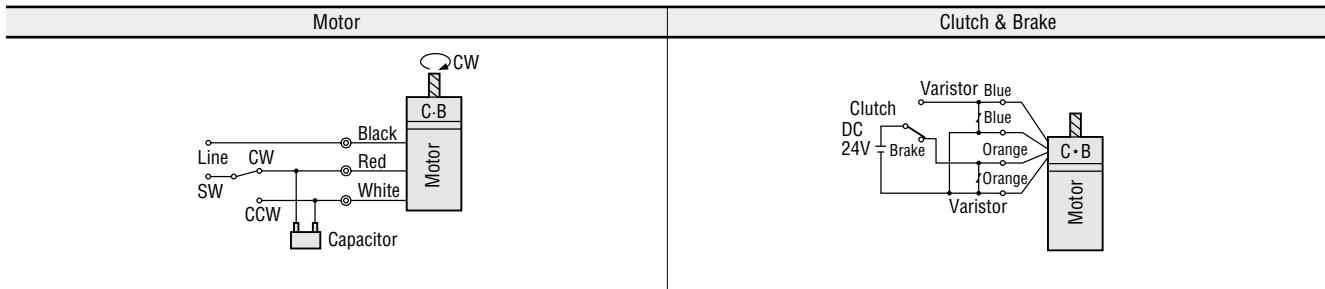

Change the direction of motor rotation only after bringing the motor to a stop.

If an attempt is made to change the direction of rotation while the motor is rotating, the motor may not reverse or it may change its direction of rotation after some delay.

**Note:** The surge absorber circuit is included with the **C·B** motor. Clutch and brake coil lead wires are non-polar.

### Type of Gearhead

Motor Type	Gearhead Model	Gear Ratio
<b>CBI540-</b>	<b>5GC□KA</b>	3.6, 6, 9, 15, 18, 30
<b>CBI560-, CBI590-</b>	<b>5GCH□KA</b>	36, 60, 90, 120, 180

Enter the gear ratio in the box (□) within the gearhead model.

**■ Dimensions** Scale 1/4, Unit = inch (mm)

- Motor **CBI540-701WU** Weight (Mass): 8.4 lb. (3.8 kg)
- Gearhead **5GC□KA** Weight (Mass): 3.3 lb. (1.5 kg)

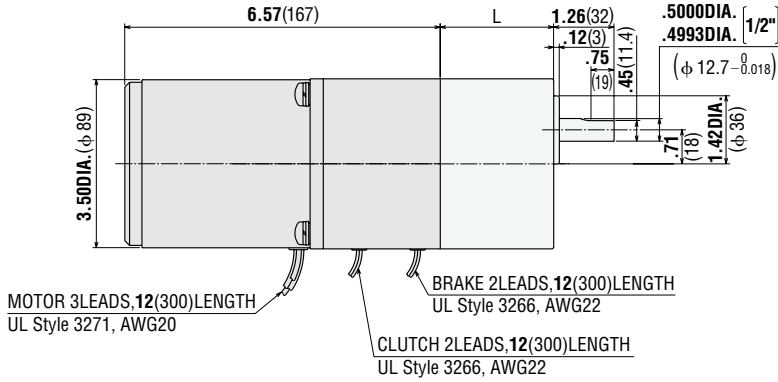

L = 1.65(42) **5GC3.6KA~18KA**  
L = 2.36(60) **5GC30KA~180KA**

- Motor **CBI560-801WU** Weight (Mass): 8.8 lb. (4.0 kg)
- Gearhead **5GCH□KA** Weight (Mass): 3.3 lb. (1.5 kg)

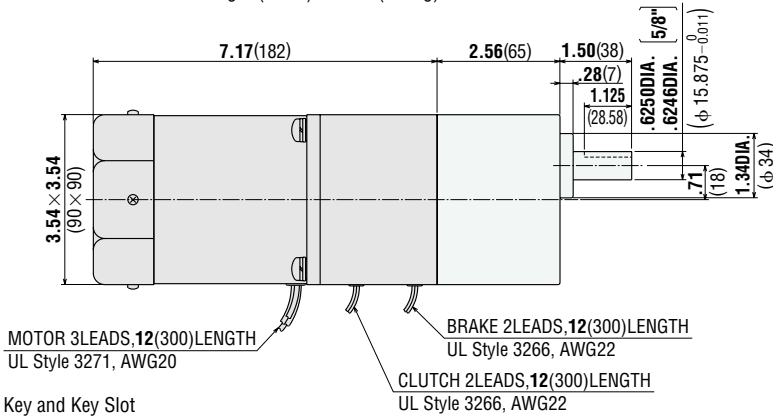

● Key and Key Slot  
The key is provided with the **5GCH□KA**

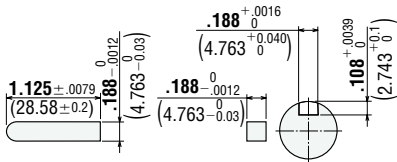

- Motor **CBI590-801WU** Weight (Mass): 9.9 lb. (4.5kg)
- Gearhead **5GCH□KA** Weight (Mass): 3.3 lb.(1.5 kg)

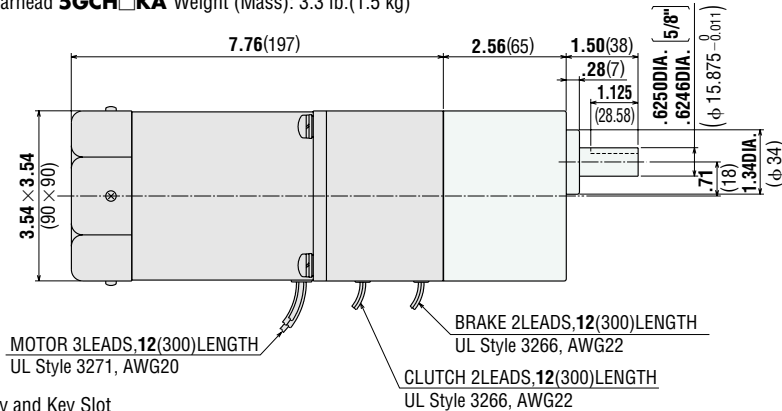

● Key and Key Slot  
The key is provided with the **5GCH□KA**

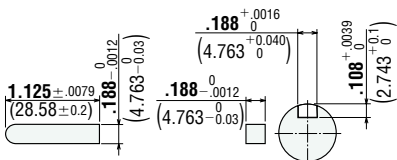

GEARHEAD CASE:  
4-.256DIA. (φ 6.5)  
CLUTCH-BRAKE CASE:  
4-M6 P1.0  
.91(23)DEEP

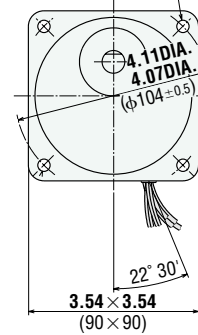

GEARHEAD CASE:  
4-.256DIA. (φ 6.5)  
CLUTCH-BRAKE CASE:  
4-M6 P1.0  
.91(23)DEEP

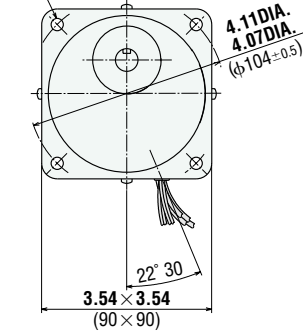

GEARHEAD CASE:  
4-.256DIA. (φ 6.5)  
CLUTCH-BRAKE CASE:  
4-M6 P1.0  
.91(23)DEEP

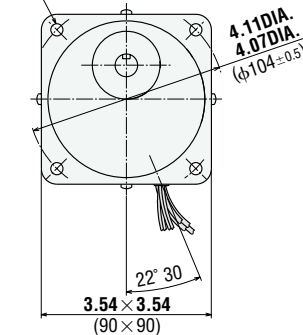



● **Capacitor** (included with the C-B motor) Unit = **inch** (mm)

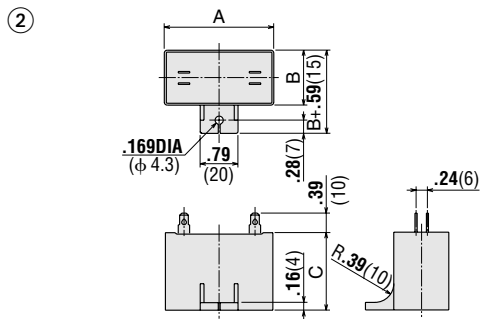
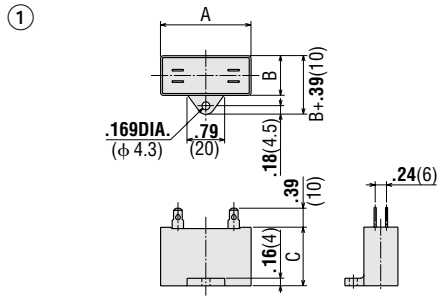

Motor Model	Capacitor Model	Dimensions inch(mm)			Weight oz (g)	No.
		A	B	C		
<b>CB1540-701WU</b>	CH90CFAUL	1.89 (48)	0.83 (21)	1.22 (31)	1.41(40)	①
<b>CB1560-801WU</b>	CH180CFAUL	2.28 (58)	0.93 (23.5)	1.46 (37)	2.47(70)	②
<b>CB1590-801WU</b>	CH200CFAUL	2.28 (58)	1.14 (29)	1.61 (41)	3.35(95)	②

Capacitor cap is provided with the capacitor.