

SPEED CONTROL MOTORS

COMPONENT *Type* SS21-UL *Type*

A tachogenerator built into induction motors, in combination with the specially designed control pack, allows multi-functional operation such as speed control, and direct control from programmable controllers.

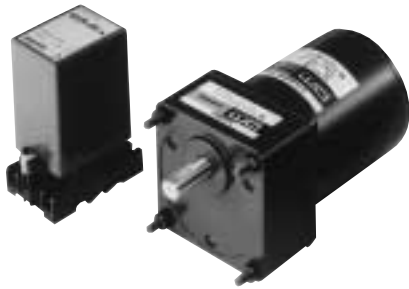

Gearhead shown in photograph is sold separately.



■ Features

- Speed control range is 90 ~ 1700 r/min.
- Each motor and control pack is recognized by UL.
- Easy electrical connections due to the plug-in pin construction.

■ Specifications



Model	SS21-UL
Voltage	AC115V±10%
Frequency	60Hz
Current	1.5A Max.
Operable Motor Output Power	6W~40W
Speed Range	90r/min~1700r/min
Ambient Temperature	32°F~104°F (0°C~40°C)
Ambient Humidity	85% Maximum. (Noncondensing)

Note that these models cannot be used for applications requiring the control of more than one motor/control-pack set by the same external potentiometer.

■ Specifications

● Induction Motors — Continuous Rating



Model		Maximum Output Power Hp	Voltage W	Frequency V AC	Speed Hz	Speed Range r/min	Torque		Starting Torque		Current A	Input W	Capacitor			
Pinion Shaft Type	Round Shaft Type						oz-in 1200r/min	mN·m 90r/min	oz-in mN·m	μF VAC						
2IK6RGN-AUL	2IK6RA-AULA	1/124	6	115	60	90~1700	6.9	50	2.5	18	4.6	33	0.25	25	2.0	250
3IK15RGN-AUL	3IK15RA-AULA	1/50	15	115	60	90~1700	11.7	84.5	4.3	31	8.3	60	0.46	38	4.0	250
4IK22RGN-AUL	4IK22RA-AULA	1/34	22	115	60	90~1700	25.0	180	8.3	60	15.3	110	0.52	50	5.0	250
5IK40RGN-AUL	5IK40RA-AULA	1/18.5	40	115	60	90~1700	25.0	180	7.6	55	27.8	200	0.83	58	8.0	250

- **2IK** type is impedance protected.
- **3IK, 4IK** and **5IK** type motors contain a built-in thermal protector. If a motor overheats for any reason, the thermal protector is opened and the motor stops. When the motor temperature drops, the thermal protector closes and the motor restarts. Be sure to turn the motor off before inspecting.
- The speed range is under no load condition.
- The UL recognized speed control motors are designed for the SS21-UL type speed control pack. Motor cannot be combined with other types of control packs.
- Note that these models cannot be used for applications requiring the control of more than one motor/control-pack set by the same external potentiometer.

■ General Specifications of Motors

Item	Specifications
Insulation Resistance	100M ohms or more when 500V DC is applied between the windings and the frame after rated motor operation under normal ambient temperature and humidity.
Dielectric Strength	Sufficient to withstand 1.5kV at 50Hz and 60Hz applied between the windings and the frame after rated motor operation under normal ambient temperature and humidity.
Temperature Rise	135°F (75°C) or less measured by the resistance change method after the temperature of the coil has stabilized under normal operation at the rated voltage and frequency.
Overheating Protection Device	Built-in thermal protector (Automatic return type) Open: 248°F±9°F (120°C±5°C) Close: 170.6°F±27°F (77°C ±15°C)
Insulation Class	Class A
Ambient Temperature Range	14°F ~ 104°F (-10°C ~ +40°C)
Ambient Humidity	85% Maximum (Noncondensing)

- **2IK** type is impedance protected. This type of motor does not contain a built-in thermal protector.

■ Permissible Torque When Gearhead Is Attached

The speed at gearhead shaft (N_G) is calculated as follows:

$$N_M = N_G \times i$$

N_M : Speed of Motor
 N_G : Speed of Gearhead
 i : Gear Ratio

The output torque at gearhead (T_G) is calculated by using the following formula:

$$T_G = T_M \times i \times \eta$$

T_G : Permissible Torque of Gearhead
 T_M : Permissible Torque of Motor
 η : Gearhead efficiency (refer to Table 2)

The output torque at the gearhead shaft must be lower than the maximum permissible torque specified right.

Maximum Permissible Torque of Gearhead

Gearhead Model	Maximum Permissible Torque
2GN□KA	26 lb-in/3 N·m
3GN□KA	43 lb-in/5 N·m
4GN□KA	69 lb-in/8 N·m (52 lb-in/6 N·m when gear ratio is 250, 300 and 360)
5GN□KA	87 lb-in/10 N·m

- Enter the gear ratio in the box (□) within the model name.

● **Table 1: Motor Speed Range**

Gear Ratio	3	3.6	5	6	7.5	9	12.5	15	18	25	30	36	50	60	75	90	100	120	150	180	
High Speed	566	472	340	283	226	189	136	113	94	68	56	47	34	28	22	19	17	14	11	9.4	
Speed r/min	}	}	}	}	}	}	}	}	}	}	}	}	}	}	}	}	}	}	}	}	}
Low Speed	30	25	18	15	12	10	7	6	5	3.6	3	2.5	1.8	1.5	1.2	1.0	0.9	0.75	0.6	0.5	

● **Table 2: Gearhead Efficiency and Direction of Gearhead Output Shaft**

Gear Ratio	3	3.6	5	6	7.5	9	12.5	15	18	25	30	36	50	60	75	90	100	120	150	180	
Model																					
2GN□KA, 3GN□KA	81%									73%			66%								
4GN□KA, 5GN□KA																					

- A colored background indicates that the output shaft of the gearmotor rotates in the same direction as the output shaft of the motor. A white background indicates rotation in the opposite direction.
- Enter the gear ratio in the box (□) within the model name.

Torque — Speed Characteristics

2IK6RGN-AUL
2IK6RA-AULA
 / **SS21-UL**

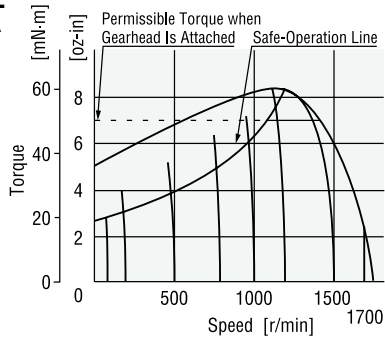

4IK22RGN-AUL
4IK22RA-AULA
 / **SS21-UL**

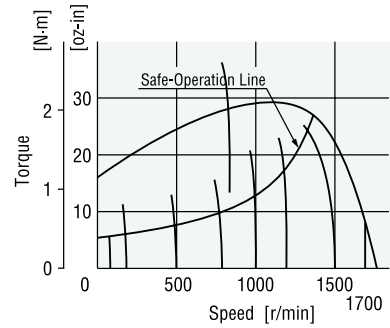

3IK15RGN-AUL
3IK15RA-AULA
 / **SS21-UL**

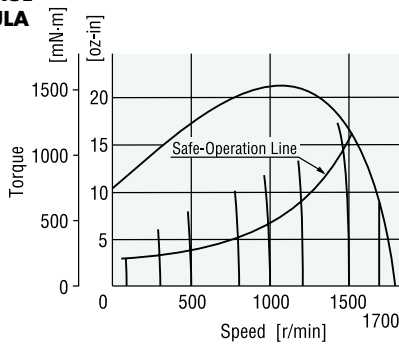

5IK40RGN-AUL
5IK40RA-AULA
 / **SS21-UL**

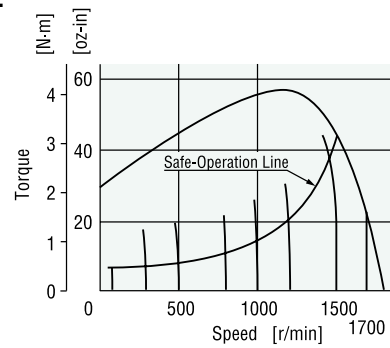

Wiring Diagrams

Uni-directional, speed control

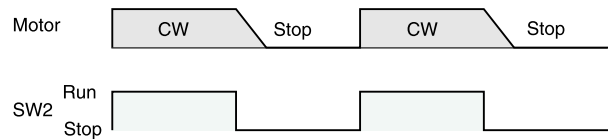
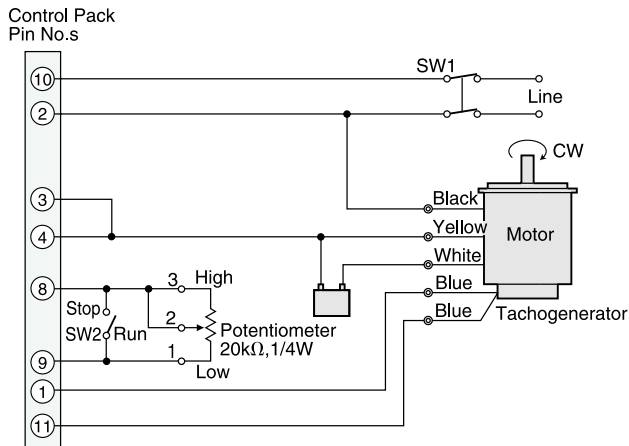

- To stop the motor for an extended period, use SW2.
- This wiring diagram provides CW rotation as viewed from the front shaft end of the motor.
- To reverse direction (CCW), reverse the yellow and white wires.
- The direction of rotation is as view from the front shaft end the motor.

● Bi-directional, speed control

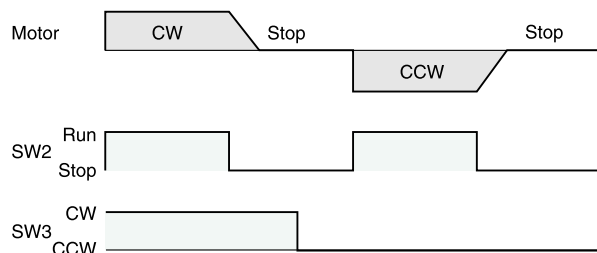
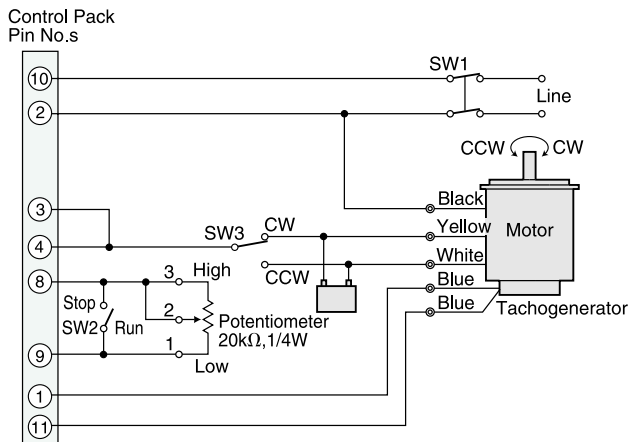

- To stop the motor for an extended period, use SW1.
- SW3 controls the direction of motor shaft rotation as viewed from the front shaft end of the motor. Change the direction of motor rotation only after bringing the motor to a stop. If an attempt is made to change the direction of rotation while the motor is rotating, the motor may ignore the reversing command or change its direction of rotation after some delay.
- To reverse direction of motor rotation, wait until the motor has stopped.
- The direction of rotation is as view from the front shaft end the motor.

Switch No.	Specifications	Accessories
SW1, SW3	AC125V, 5A minimum	—
SW2	DC20V, 10mA minimum	—

■ Speed Control

● Setting The Speed

The speed is set by either an external potentiometer. These values correspond to the minimum and the maximum setting of the speed potentiometer used for speed control. Motor speed can be adjusted over the range from 90 r/min to 1700 r/min at 60Hz.

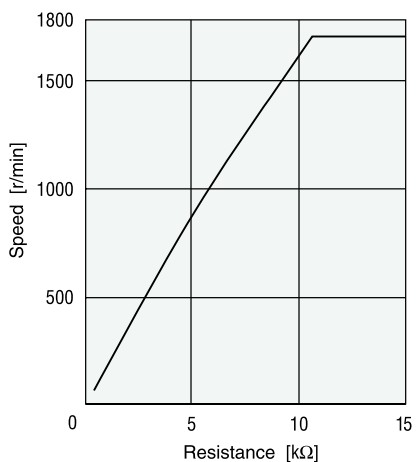

Speed Setting Resistance — Speed Characteristics

Note: The speed control inputs of the control packs must be isolated from each other. Therefore, only one control pack at a time can be controlled by a single potentiometer.

■ Dimensions Scale 1/4, Unit = inch (mm)

2IK6RGN-AUL

Weight (Mass): 1.76 lb.(0.8 kg)

2GN□KA

Weight (Mass): 0.88 lb.(0.4 kg)

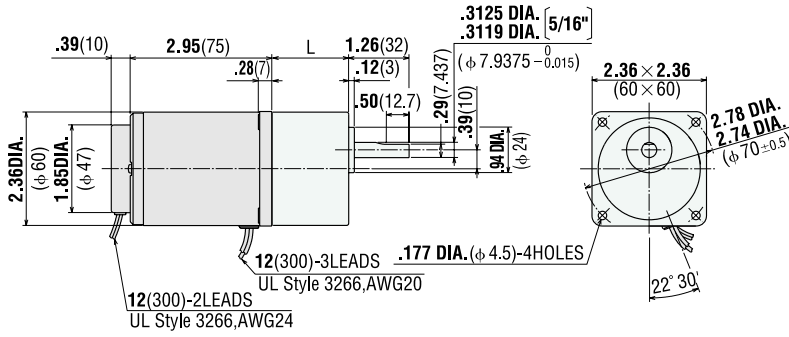

L=1.18 (30) **2GN3KA~18KA**
L=1.57 (40) **2GN25KA~180KA**

2IK6RA-AULA

Weight (Mass): 1.76 lb.(0.8 kg)

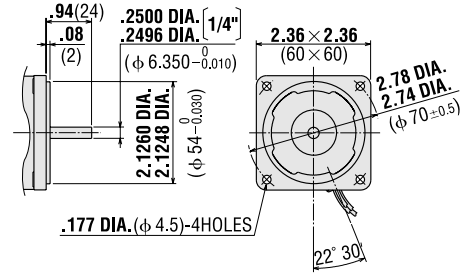

3IK15RGN-AUL

Weight (Mass): 2.65 lb.(1.2 kg)

3GN□KA

Weight (Mass): 1.21 lb.(0.55 kg)

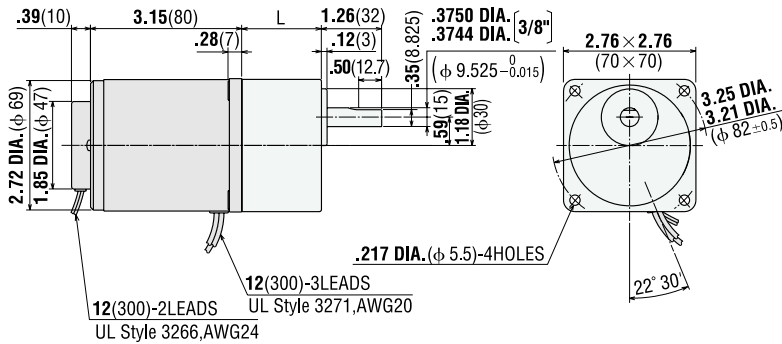

L=1.26 (32) **3GN3KA~18KA**
L=1.65 (42) **3GN25KA~180KA**

3IK15RA-AULA

Weight (Mass): 2.65 lb.(1.2 kg)

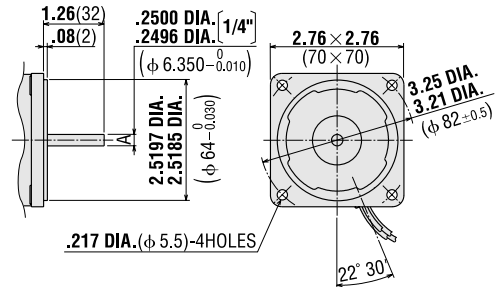

4IK22RGN-AUL

Weight (Mass): 3.53 lb.(1.6 kg)

4GN□KA

Weight (Mass): 1.43 lb.(0.65 kg)

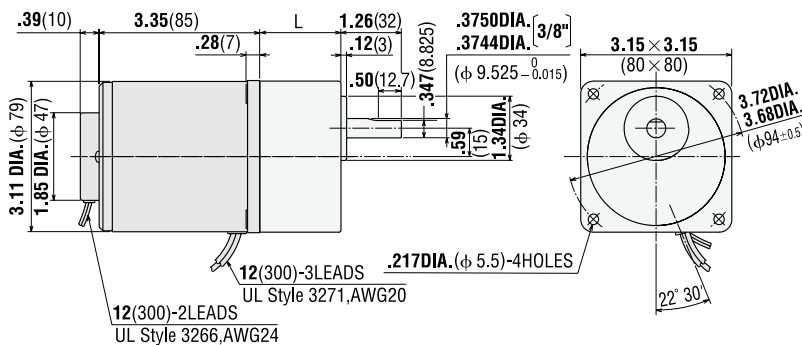

L=1.26 (32) **4GN3KA~18KA**
L=1.67 (42.5) **4GN25KA~180KA**

4IK22RA-AULA

Weight (Mass): 3.53 lb.(1.6 kg)

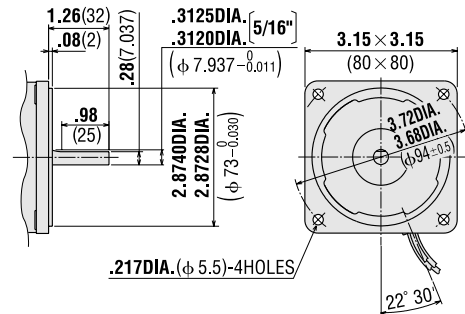

5IK40RGN-AUL

Weight (Mass): 5.73 lb.(2.6 kg)

5GN□KA

Weight (Mass): 3.3 lb.(1.5 kg)

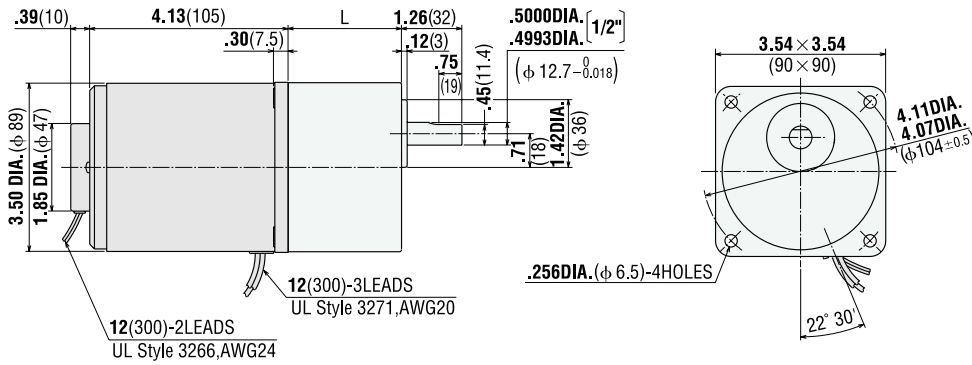

L=1.65 (42) **5GN3KA~18KA**
L=2.36 (60) **5GN25KA~180KA**

5IK40RA-AULA

Weight (Mass): 5.73 lb.(2.6 kg)

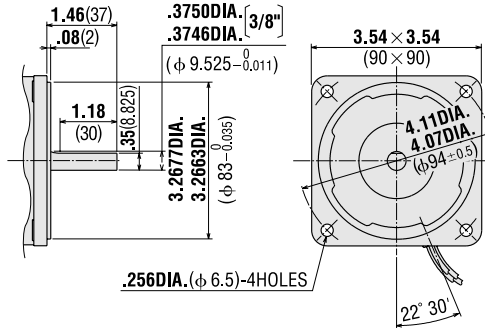

● **Capacitor** (included with the motor)

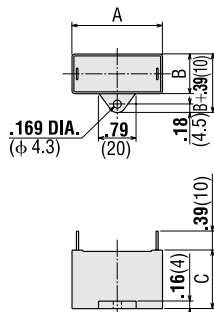

Motor Model	Capacitor Model	Dimensions inch (mm)			Weight oz (g)
		A	B	C	
2IK6RGN-AUL	CH20UL	1.22	.57	.93	0.53 15
2IK6RA-AULA		(31)	(14.5)	(23.5)	
3IK15RGN-AUL	CH40UL	1.46	.71	1.06	0.88 25
3IK15RA-AULA		(37)	(18)	(27)	
4IK22RGN-AUL	CH50UL	1.50	.75	1.14	1.06 30
4IK22RA-AULA		(38)	(19)	(29)	
5IK40RGN-AUL	CH80UL	1.50	.83	1.22	1.23 35
5IK40RA-AULA		(38)	(21)	(31)	

Capacitor cap is provided with the capacitor.

■ **Speed Control Pack Dimensions**

Scale 1/4, Unit = inch (mm)

SS21-UL Weight (Mass): 0.33 lb.(0.15 kg)

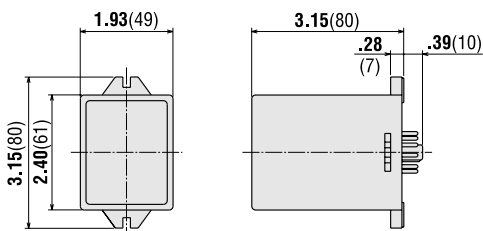

● **Potentiometer**

PAVR-20KY Scale 1/2, Unit = inch (mm)

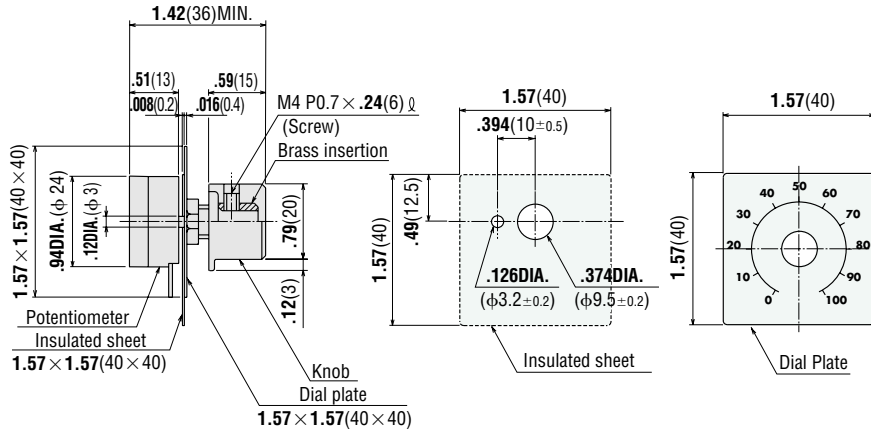

● **Socket**

EP11PF Scale 1/4, Unit = inch (mm)

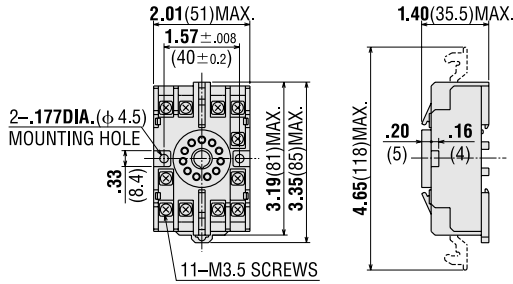

■ **Accessories (Sold separately)**

● **Speed Indicator**

To check the motor speed visually, connect a speed indicator, model **SDM496** (sold separately). See page A-269 for more detail.



SDM496 can also indicate the speed at the gearhead shaft.

